



# Installation instructions sonnenBatterie eco 8.0 – for authorised electricians–

**IMPORTANT**

- ▶ Read this documentation carefully before installation.
- ▶ Retain this document for reference purposes.

**Publisher**

---

sonnen GmbH

---

Am Riedbach 1

---

87499 Wildpoldsried, Germany

---

Emergency hotline +49 (0)83 049 2933 444

---

Email info@sonnenbatterie.de**Document**

---

Document number KD-291

---

Item number 52205

---

Version X01

---

Publication date 27.09.2016**Scope of validity**

---

This document relates to the following product:

---

Product designation sonnenBatterie eco 8.0

# Table of contents

<b>1 Information about this document.....</b>	<b>6</b>
1.1 Target group of this document.....	6
1.2 Designations in this document.....	6
1.3 Explanation of symbols.....	6
<b>2 Safety.....</b>	<b>7</b>
2.1 Intended Use.....	7
2.2 Requirements for the electrician.....	7
2.3 General safety information.....	7
2.3.1 Danger due to incorrect operation.....	7
2.3.2 Danger to life due to explosive and flammable materials.....	8
2.3.3 About repairs on the storage system.....	8
2.3.4 Danger to life due to product modifications or changes to the product environment.....	8
2.3.5 Conduct in case of a fire / Important information for fire services.....	8
2.4 Regulations (directives, laws, standards).....	9
2.5 Warnings.....	9
<b>3 Product description.....</b>	<b>12</b>
3.1 Technical data.....	12
3.2 System components.....	13
3.3 Type plate.....	14
<b>4 Transport and storage.....</b>	<b>15</b>
4.1 Storage.....	15
4.1.1 Ambient conditions during storage.....	15
4.1.2 Storing the battery modules.....	15
4.2 Transport.....	15
4.2.1 Ambient conditions during transport.....	15
4.2.2 Transporting battery modules.....	15
4.2.3 Inspecting for transport damage.....	16
4.2.4 Temperature adjustment after transport.....	18
<b>5 Installation.....</b>	<b>19</b>
5.1 Scope of delivery.....	19
5.2 Selecting the installation location.....	20
5.2.1 Requirements for the installation location.....	20
5.2.2 Observing minimum distances.....	20
5.3 Opening the doors of the main cabinet.....	20
5.4 Removing the cover of the extension cabinet.....	21
5.5 Removing the filter plates.....	21

5.6 Installing the storage system.....	22
5.6.1 Using the correct mounting materials.....	22
5.6.2 Placing the levelling mat or the pedestal.....	22
5.6.3 Drilling the holes.....	23
5.6.4 Mounting the storage system.....	24
<b>6 Electrical connection.....</b>	<b>26</b>
6.1 Working on the electrical distributor.....	27
6.1.1 Placing components in the distributor.....	27
6.1.2 Wiring components in the electrical distributor.....	27
6.2 Connecting the Ethernet cable.....	31
6.3 Connecting the Modbus cable.....	32
6.4 Connecting the mains line.....	33
6.5 Using digital outputs.....	34
6.5.1 Connecting the signal line.....	35
6.5.2 Using the 'PV reduction' digital outputs.....	36
6.5.3 Using the 'self-consumption switch' digital output.....	38
6.5.4 Using the 'min/max SoC' digital output.....	39
6.6 Using accessories.....	40
6.6.1 Using 'heat pump control'.....	40
6.7 Installing the battery modules.....	43
6.7.1 Measuring the battery module voltages.....	44
6.7.2 Numbering the battery modules.....	44
6.7.3 Defining the communication addresses.....	44
6.7.4 Setting the termination switches.....	44
6.7.5 Positioning the battery modules.....	45
6.7.6 Connecting the DC lines.....	46
6.7.7 Connecting the BMS communication line.....	49
6.7.8 Attaching the fuse plugs.....	51
6.7.9 Entering the battery capacity/nominal power on the type plate.....	51
6.8 Mounting filter plates and cover.....	52
6.8.1 Mounting filter plates.....	52
6.8.2 Connecting earthing conductor.....	53
6.8.3 Mounting cover.....	53
<b>7 Commissioning.....</b>	<b>54</b>
7.1 Initial commissioning.....	54
7.1.1 Commissioning checklist.....	54
7.1.2 Commissioning report.....	54
7.2 Switching on the storage system.....	55

7.2.1 Removing the cover.....	55
7.2.2 Switching on the storage system.....	55
7.3 Running the commissioning wizard.....	56
7.3.1 Establishing connection to storage system.....	57
7.3.2 Running the commissioning wizard.....	58
<b>8 Troubleshooting.....</b>	<b>59</b>
<b>9 Decommissioning.....</b>	<b>60</b>
<b>10 Uninstallation and disposal.....</b>	<b>61</b>
10.1 Uninstallation.....	61
10.2 Disposal.....	61
<b>11 Commissioning report.....</b>	<b>63</b>

# 1 Information about this document

This document describes the installation of the sonnenBatterie eco 8.0.

Observe the following points:

- ▶ Read this document in its entirety before beginning the installation work.
- ▶ Keep this document in the vicinity of the sonnenBatterie.

## 1.1 Target group of this document

This document is intended for authorised electricians.

The actions described here must only be performed by authorised electricians.

## 1.2 Designations in this document

The following designations are used in this document:

Table 1:  
Designations in this document

Complete designation	Designation in this document
sonnenBatterie eco 8.0	storage system

## 1.3 Explanation of symbols



Extremely dangerous situation leading to certain death or serious injury if the safety information is not observed.



Dangerous situation leading to potential death or serious injury if the safety information is not observed.



Dangerous situation leading to potential injury if the safety information is not observed.



Indicates actions that may cause material damage.



Important information not associated with any risks to people or property.

Table 2:  
Additional symbols

Symbol	Meaning
▶	Work step
1. 2. 3. ...	Work steps in a defined order
•	List

## 2 Safety

### 2.1 Intended Use

The sonnenBatterie eco 8.0 is a battery storage system which can be used to store electrical energy. Improper use of this system poses a risk of death or injury to the user or third parties as well as damage to the product and other items of value.

The following points must therefore be observed in order to comply with the intended use of the product:

- The storage system must be fully installed in accordance with the installation instructions.
- The storage system must be installed by a qualified electrician.
- The storage system must only be used at a suitable installation location.
- The transport and storage conditions must be observed.



---

Failure to comply with the conditions of the warranty and the information specified in this document invalidates any warranty claims.

---

### 2.2 Requirements for the electrician

The storage system must only be installed and commissioning by authorised electricians. Authorised electricians must meet the following criteria:

- The company for which the electrician works must be certified by sonnen GmbH.
- The electrician must be considered competent and registered to work to the UK national safety standard (BS 7671).
- The electrician must have successfully complete sonnen GmbH certification training for this product.

### 2.3 General safety information

- ▶ Only use the storage system in its original state – without any unauthorised modifications – and when it is in proper working order.
- ▶ Ensure that all protective devices are working properly.

#### 2.3.1 Danger due to incorrect operation

Incorrect operation puts you and others at risk and could cause material damage.

- ▶ Read through these instructions and all further applicable documents carefully, paying special attention to the chapters on safety and warnings.

The device must not be opened during operation.

Manipulating the cabling inside can lead to short circuits/arcs during operation, thus posing a risk of burns and electrocution.

### 2.3.2 Danger to life due to explosive and flammable materials

- ▶ Do not use the storage system in potentially explosive environments.

### 2.3.3 About repairs on the storage system

All repairs on the storage system must be performed by certified service technicians only.

### 2.3.4 Danger to life due to product modifications or changes to the product environment

- ▶ Never block or bypass the protective devices.
- ▶ Never modify the protective devices.
- ▶ Do not make changes to the storage system.
- ▶ Do not make changes to the electrical and data supply lines.

### 2.3.5 Conduct in case of a fire / Important information for fire services

Fire may occur with electrical equipment despite its careful design. Likewise, a fire in the vicinity of the equipment can cause the storage system to catch fire, releasing the contents of the battery modules.

- ▶ Observe the warnings about the risk of injury/burns due to the escape of electrolyte (see section 2.5 – pg. 9).

In the event of a fire in the vicinity of the product or in the storage system itself, proceed as follows:

- ▶ Only firefighters with appropriate protective equipment (safety gloves, safety clothing, face guard, breathing protection) are permitted to enter the room where the burning storage system is located.

There is a danger of electrocution when extinguishing fire while the storage system is switched on. Therefore, before starting to extinguish the fire:

- ▶ Switch off the storage system.
- ▶ Switch off the mains fuses in the building.

If the storage system and/or mains fuses cannot be safely switched off:

- ▶ Observe the minimum distances specified in DIN VDE 0132 for the extinguishing agent used.

The storage system works with an output voltage of 400 V (AC) and is therefore considered a low-voltage system.

- ▶ A storage system fire can be extinguished using conventional extinguishing agents.
- ▶ Water is recommended as an extinguishing agent in order to cool the battery modules and therefore prevent thermal runaway in battery modules which are still intact.



Information on the battery modules:

- The battery modules have a nominal voltage of 51.2 V (DC) and therefore fall into the range of protected extra-low voltage (under 60 V DC).
- The battery modules do not contain metallic lithium.



Further information can be found in the following document: *Merkblatt für Einsatzkräfte – Einsatz an stationären Lithium Solarstromspeichern* (Information sheet for electricians – Use on stationary lithium solar energy storage systems, published by the German Solar Association, or BSW – Bundesverband der Solarwirtschaft e.V.)

## 2.4 Regulations (directives, laws, standards)

► Observe all relevant, currently applicable national regulations, especially the following:

- Regulations of the local power supply companies.

This list presents only a selection and does not claim to be exhaustive. The authorised electrician is responsible for knowing and observing all of the regulations relevant to their work.

## 2.5 Warnings

This section contains specific warnings that must always be observed when working with the product.

### DANGER

#### **Danger to life due to electrocution!**

Touching components inside the storage system poses a danger to life due to electrocution.

- Do not touch any components.
- Do not remove any plastic covers.
- Never reach below covers.

### DANGER

#### **Danger to life due to electrocution!**

When carrying out electrical work on the storage system, the following must be observed:

- Switch off the storage system.
- Disconnect the relevant electrical circuits.
- Secure against anyone switching on the device again.
- Check that the device is disconnected from the power supply.
- Only authorised electricians are permitted to carry out electrical work.

**WARNING****Risk of burns!**

Very high short-circuit currents are possible.

The following must be observed when working with the battery modules:

The battery module is activated when the fuse connector is plugged in. The voltage runs between the plus and minus contacts of the battery module (nominal voltage of battery modules: 51.2 V DC). The battery module is deactivated when the fuse connector is unplugged. No voltage runs between the plus and minus contacts of the battery module. If all interconnected battery modules are deactivated, it is safe to work on a battery module.

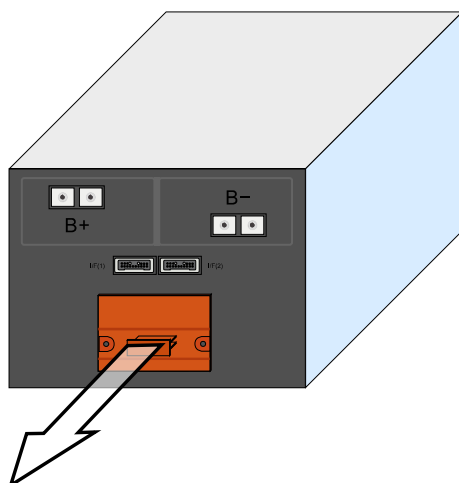

When working on the DC circuit:

- ▶ Set aside metal jewellery.
- ▶ Switch off the storage system.
- ▶ Switch off the series fuse.
- ▶ Remove the orange fuse connectors on all battery modules.

 **WARNING****Risk of injury and burns due to the escape of electrolyte**

The battery modules installed in the storage system are protected by multiple protective devices and can be operated safely.

Despite their careful design, the battery cells inside the battery modules may corrode or experience thermal runaway in the event of mechanical damage, heat or a fault.

This can have the following effects:

- High heat generation on the surface of the battery cells.
- Electrolyte may escape.
- The escaping electrolyte may ignite and cause an explosive flame.
- The smoke from burning battery modules can irritate the skin, eyes and throat.

Therefore, proceed as follows:

- ▶ Do not open the battery modules.
- ▶ Do not mechanically damage the battery modules (pierce, deform, strip down, etc.)
- ▶ Do not modify the battery modules.
- ▶ Do not allow the battery modules to come into contact with water (except when extinguishing a fire in the storage system).
- ▶ Do not heat the battery modules. Operate them only within the permissible temperature range.
- ▶ Do not short-circuit the battery modules. Do not allow them to come into contact with metal.
- ▶ Do not continue to use the battery modules after a short circuit.
- ▶ Do not deep-discharge the battery modules.

In the event that module contents are released:

- ▶ Do not enter the room under any circumstance.
- ▶ Avoid contact with the escaping electrolyte.
- ▶ Contact the fire services.

**Notice****Deep-discharge of the battery modules**

Destruction of the battery modules!

- ▶ Do not disconnect the storage system from the public grid for long periods of time.
- ▶ Never continue to operate battery modules which have been deep-discharged.

## 3 Product description

### 3.1 Technical data

sonnenBatterie	eco 8.0/2	eco 8.0/4	eco 8.0/6	eco 8.0/8	eco 8.0/10	eco 8.0/12	eco 8.0/14	eco 8.0/16
<b>System data (AC)</b>								
Nominal voltage	400 V							
Nominal frequency	50 Hz							
Nominal power	1,500 W	2,500 W	3,000 W	3,300 W	3,300 W	3,300 W	3,300 W	3,300 W
Nominal current	2,2 A	3,6 A	4,5 A	4,8 A	4,8 A	4,8 A	4,8 A	4,8 A
Mains connection	three-phase, L1 / L2 / L3 / N / PE							
Mains topology	TN / TT							
Mains connection fuse	miniature circuit breaker   type B   10 A - 16 A							
<b>Battery data (DC)</b>								
Cell technology	lithium iron phosphate (LiFePO <sub>4</sub> )							
Usable capacity	2.0 kWh	4.0 kWh	6.0 kWh	8.0 kWh	10 kWh	12 kWh	14 kWh	16 kWh
Nominal voltage	51.2 V							
<b>Dimensions / weight with small extension cabinet (from 2 kWh up to 10 kWh)</b>								
Dimensions (H/B/T) in cm	70/64/22	137/64 /22	137/64 /22	137/64 /22	137/64 /22	-	-	-
Weight in kg	53	88	115	142	169	-	-	-
<b>Dimensions / weight with big extension cabinet (from 2 kWh up to 16 kWh)</b>								
Dimensions (H/B/T) in cm	70/64/22	184/64 /22	184/64 /22	184/64 /22	184/64 /22	184/64 /22	184/64 /22	184/64 /22
Weight in kg	53	93	120	147	174	201	228	255
<b>Power meter</b>								
Voltage measurement inputs	Nominal voltage (AC): 230 V (L-N), 400 V (L-L)   max. connectible conductor cross-section: 1.5 mm <sup>2</sup>							
Clamp-on current transformer	Max. measurable current: 60 A							
<b>Safety</b>								
Protection class	I (PE conductor)							
Degree of protection	IP21							
<b>Ambient conditions</b>								
Ambient temperature range	5°C ... 30°C							
Storage temperature range	0°C ... 40°C							
Transport temperature range	-15 °C ... 40°C							
Max. rel. humidity	90%							
Permissible installation altitude	2000 m above sea level							
Additional ambient conditions	<ul style="list-style-type: none"> <li>• Installation room can be ventilated</li> <li>• Free from vibrations</li> <li>• Free from dust (especially flour dust or sawdust)</li> <li>• Free from corrosive and explosive gases (ammonia content max. 20 ppm)</li> <li>• No direct sunlight</li> <li>• Even floor, suitable for heavy loads</li> <li>• Free access to the installation location</li> <li>• The currently applicable building codes must be observed</li> </ul>							

Table 3: Technical data

## 3.2 System components

Figure 1:  
System components

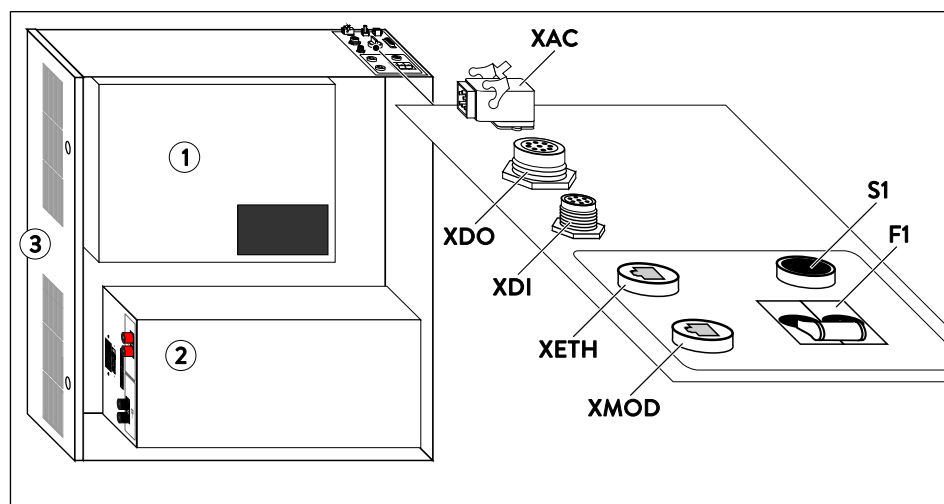

Table 4:  
System components

No.	Designation	Function
1	Battery inverter	Conversion of batteries' direct current into alternating current
2	Battery module	Storage of electrical power
3	Filter plate	Holder for filter pad
F1	fuse switch	On/off switch for storage system
XAC	Mains connection socket	Sending and receipt of digital signals
XDI	Digital inputs	Interface to receive digital signals
XDO	Digital outputs	Interface to emit digital signals
XETH	Ethernet port	Data connection to router for home network
XMOD	Modbus port	Data connection to power meter
S1	switch	Pressed during the switch-on procedure (see section 7.2 – pg. 55).

### 3.3 Type plate

The type plate for the storage system is located on the outer surface of the system. The type plate can be used to uniquely identify the storage system. The information on the type plate is required for the safe use of the system and for service matters.

The following information is specified on the type plate:

- Item designation
- Item number
- Version (hardware version)
- Technical data of the storage system

The nominal power and battery capacity of the storage system differ depending on the number of battery modules installed. For this reason the nominal power and battery capacity must be entered on the type plate by the electrician installing the system.

## 4 Transport and storage

### 4.1 Storage

Storage describes the condition when the storage system is not connected to the public electrical mains and the battery modules cannot be automatically charged.

#### 4.1.1 Ambient conditions during storage

The ambient conditions specified in Tabular 3 (pg. 12) must be observed during storage.

#### 4.1.2 Storing the battery modules

### Notice

#### Damage/destruction of battery modules due to deep-discharge!

During storage the battery modules automatically discharge at a minimal level. Deep-discharge could damage or destroy the battery modules. For this reason, the battery modules can only be stored for a limited amount of time.

Observe the following points:

- The battery modules must be charged to 85% (charging status upon delivery) when stored.
- Store the battery modules for no longer than 6 months.
- Install the battery modules in the storage system after 6 months at the most and commission the storage system.
- During storage the orange fuse plug must not be plugged into any battery module.

### 4.2 Transport

#### 4.2.1 Ambient conditions during transport

The ambient conditions specified in Tabular 3 (pg. 12) must be observed during transport.

#### 4.2.2 Transporting battery modules

### CAUTION

#### Improper transport of battery modules

Fire outbreak at battery modules or emission of toxic substances!

- ▶ Transport the battery modules in their original packaging only. If you no longer have the original packaging, new packaging can be requested from sonnen GmbH.
- ▶ Never transport damaged battery modules.

Lithium-ion batteries are hazardous goods. Therefore the following points must be observed when transporting the battery modules:

- ▶ Observe the general transport regulations based on the mode of transport as well as all legal regulations.
- ▶ Consult an external hazardous goods expert.

The battery module data relevant for transport is provided in the following:

- Hazardous goods class: 9
- UN number: UN3480 'lithium-ion batteries'
- Battery module mass (including packaging): 29 kg

### 4.2.3 Inspecting for transport damage

#### CAUTION

##### Use of damaged battery modules

Fire outbreak at battery modules or emission of toxic substances!

- ▶ Unpack the battery modules immediately after transport and inspect them for transport damage.

If damage (deformation, damage to the housing, emission of substances and the like) is discovered:

- ▶ Do not use the battery modules under any circumstance.
- ▶ Inform the service team.

#### CAUTION

##### Insulation fault when storage system is damaged

Danger of electric shock when touching damaged insulation elements!

- ▶ Unpack the storage system immediately after transport and inspect it for transport damage.
- ▶ Do not use a damaged storage system under any circumstance.

Paragraph 425 of the German Commercial Code (*Handelsgesetzbuch*) forms the legal basis for processing transport damage.

The shipping company can only be held liable for transport damage if it can be proven that the damage occurred during the course of transport. For this reason it is important to follow the instructions given here as closely as possible.

Transport damage is divided into open and hidden damage. Open damage is externally visible damage to the transported goods or their packaging. Hidden damage occurs when the packaging is not damaged but the transported goods inside are.

Open transport damage must be reported to the shipping company immediately.

The following timeframes apply in the case of hidden transport damage:

- Deutsche Post / DHL / parcel services: report damage within 24 hours
- Shipping company: report damage within 7 days

Proceed as follows:

#### 1 Check the shipping documents

- ▶ Check the recipient address and number of shipped goods in the presence of the



shipper.

## 2 Inspect the goods for open damage

► Inspect the packaging and transport goods for external damage in the presence of the shipper.

If damage is discovered:

► Inspect the goods for hidden damage in the presence of the shipper.

Figure 2:  
Transport indicator affixed to the  
packaging

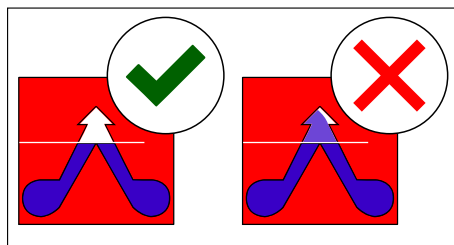

► Check the transport indicator affixed to the packaging of the main cabinet in the presence of the shipper.

The storage system has not been transported properly if blue powder has been transferred into the arrow of the transport indicator.

► Refuse to accept the goods if blue powder has been transferred into the arrow of the transport indicator.

## 3 Inspect the goods for hidden damage

This inspection should also take place in the presence of the shipper if possible.

► Unpack the goods.

► Inspect the goods for hidden (not immediately visible) transport damage.

If transport damage is discovered:

► Stop unpacking the product.

► Collect photographic evidence of the damage.

► Refuse to accept the goods if the discovered defects are serious.

## 4 Document the defects

► Document the defects identified on the consignment note.

The documentation should include the following:

- Notation 'Conditional acceptance'
- Registration number of the delivery vehicle
- Signature of the shipper

## 5 Report the damage

► Report the damage to the responsible transport company and the manufacturer immediately.

► Send the consignment note/delivery note with the shipper's confirmation of the damage and photographic evidence to the manufacturer by email.



Damage claims cannot be settled if the abovementioned documentation is not submitted within the stated reporting timeframes.

**Notice**

#### 4.2.4 Temperature adjustment after transport

---

##### Damage to the storage system due to condensation

If the temperature of the storage system is lower than the ambient temperature of the room when it is delivered, condensation may form inside the storage system. This may damage the storage system.

- ▶ Check the inside of the storage system for condensation before installation.
- ▶ Only install the storage system if there is no condensation on the surfaces.

If the storage system has been transported in sub-zero temperatures, proceed as follows:

1. Set up the storage system in a suitable location.
  2. Open all control cabinet doors.
  3. Leave the storage system to stand for at least 24 hours with open control cabinet doors.
  4. Only then can you commission the storage system.
-

# 5 Installation

## 5.1 Scope of delivery

► Check the following scope of delivery to ensure it is complete.

Abbildung 3:  
Scope of delivery

- 1 Scope of delivery for main cabinet
- 2 Scope of delivery for battery module
- 3 Scope of delivery for big extension cabinet (up to 16 kWh)
- 4 Scope of delivery for small extension cabinet (up to 10 kWh)
- 5 Scope of delivery for pedestal

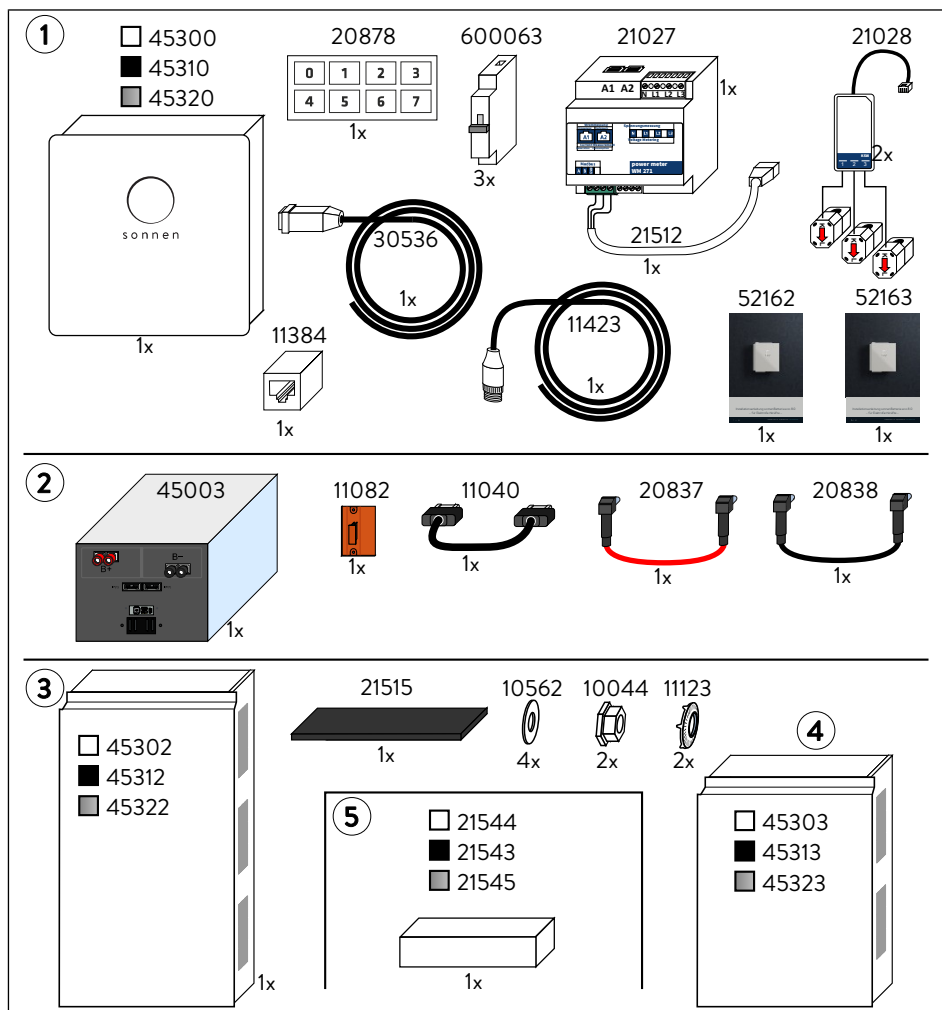

10044	Self-locking nur
10562	Washer
11040	BMS communication line 30 cm
11082	Fuse plug
11123	Locking nut
11384	RJ45 coupling
11423	Contact disc
20837	DC line red
20838	DC line black
20878	Sticker numbering for battery modules
21027	Power meter
21028	KSW60-3 current transformer
21512	Modbus line
21515	Levelling mat
21543	Pedestal (color black)
21544	Pedestal (color white)

21545	Pedestal (color silver)
30536	AC cable
21724	Earth conductor
45003	Battery module
45302	Big extension cabinet (color white)
45312	Big extension cabinet (color black)
45322	Big extension cabinet (color silver)
45303	Small extension cabinet (color white)
45313	Small extension cabinet (color black)
45323	Small extension cabinet (color silver)
45300	Main cabinet (color white)
45310	Main cabinet (color black)
45320	Main cabinet (color silver)
52163	Operating instructions
52162	Installation instructions
600063	B6 miniature circuit breaker

## 5.2 Selecting the installation location

### 5.2.1 Requirements for the installation location

- Observe the required ambient conditions (see Table 3: Technical data – pg. 12).

### 5.2.2 Observing minimum distances

Figure 4:  
Minimum distances

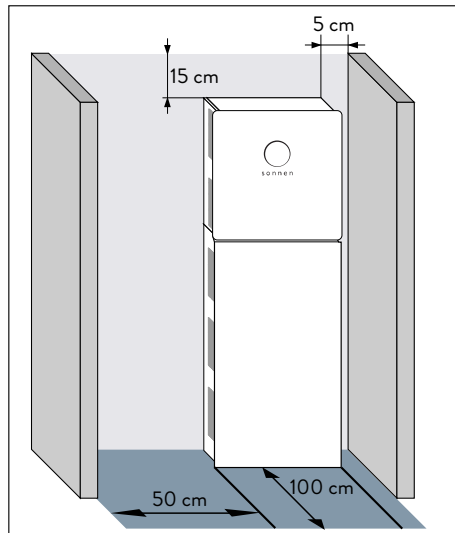

- Observe the specified minimum distances to neighbouring objects.

The minimum distances ensure that:

- there is sufficient heat dissipation,
- the storage system door can be opened easily and
- there is sufficient space for maintenance work.

## 5.3 Opening the doors of the main cabinet

Figure 5: Opening the doors of the main cabinet

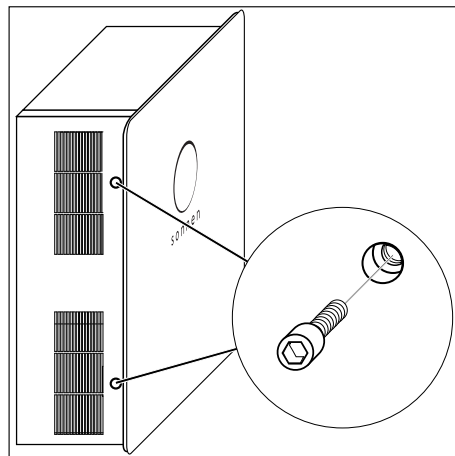

- Remove the two Allen screws on the left side of the main cabinet.

The doors can then be opened.

## 5.4 Removing the cover of the extension cabinet

Figure 6: Removing the cover of the optional extension cabinet

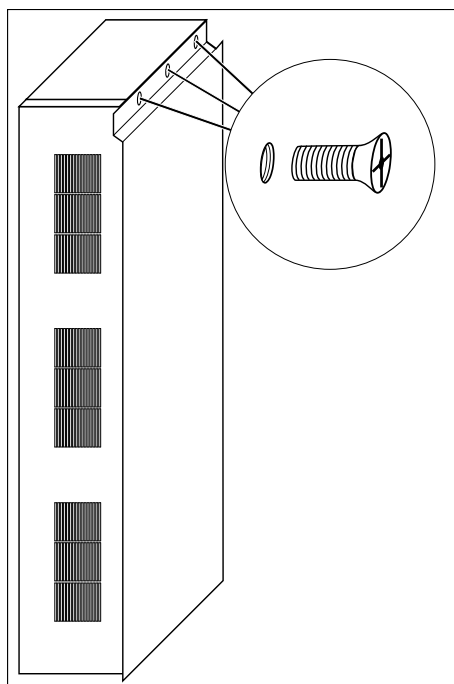

To remove the cover of the optional extension cabinet:

- ▶ Remove the three screws.
- ▶ Slide the cover up.

## 5.5 Removing the filter plates

Figure 7: Removing the filter plates

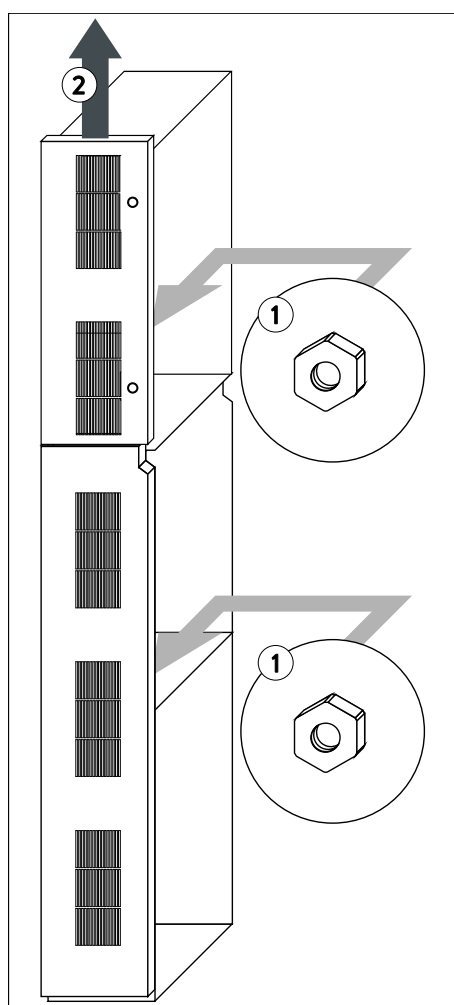

The filter plates of the main and optional extension cabinet can be removed. Removing them makes it easier to install the battery modules later.

- ▶ Remove the nuts (1) inside the main and extension cabinet.
- ▶ Slide the covers up (2) and take off the cover and place it to the side.

## 5.6 Installing the storage system

This chapter describes how to install the storage system.

Figure 8:

Left: storage system with optional extension cabinet (floor-mounted)

Right: storage system without optional extension cabinet (wall-mounted)

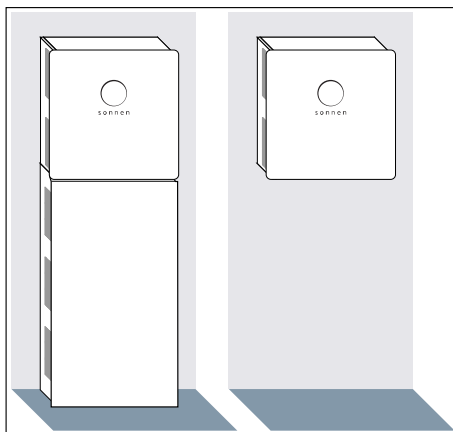

A storage system with the optional extension cabinet must be floor-mounted.

A storage system without the optional extension cabinet must be mounted to the wall with screws.

### 5.6.1 Using the correct mounting materials

► Use only screws with the following properties:



Abbildung 9: Parameters of the screws used

- The diameter of the screw head must be between 13 mm and 15 mm.
- The screw diameter must be 8 mm.
- The screw head must not exceed 5 mm.

### 5.6.2 Placing the levelling mat or the pedestal

The levelling mat (1) is part of the scope of delivery for the extension cabinet. It is used to compensate uneven floors.

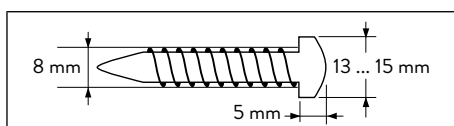
Alternatively the extension cabinet can be placed on an optional pedestal (3) instead of the levelling mat. This is helpful if the extension cabinet doesn't meet flush with the wall (e.g. because a skirting board is mounted).

Figure 10:

The levelling mat (1) compensates uneven floors. The optional pedestal (3) can e.g. be used in combination with a skirting board (2)

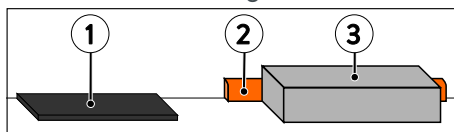

► Place the levelling mat or the pedestal at the preferred installation location.

### 5.6.3 Drilling the holes

Holes must be drilled into the wall to mount the storage system. The arrangement of the holes depends on whether the big or the small extension cabinet is used.

#### With small extension cabinet (up to 10 kWh)

Figure 11: Drill template for storage systems with small extension cabinet (figure is not to scale – all specifications are in millimetres)

- |   |  |
|---|--|
| A | Main cabinet   |
| B | Small extension cabinet  |
| C | Levelling mat (height: 10 mm) or pedestal (optional – height: 80 mm) |

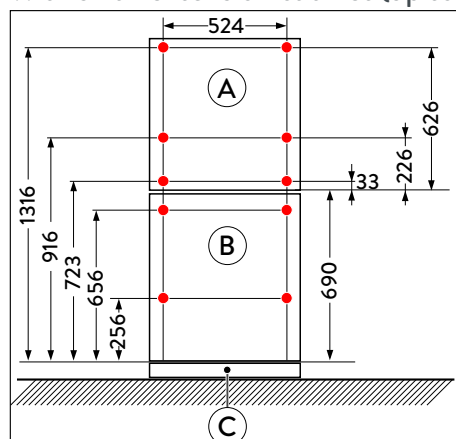

For storage systems consisting of main and small extension cabinet:

- ▶ Drill the holes shown in red in figure on the left.
- ▶ Note that the storage system must be placed on the levelling mat or the pedestal (C).

#### With big extension cabinet (up to 16 kWh)

Figure 12: Drill template for storage systems with big extension cabinet (figure is not to scale – all specifications are in millimetres)

- |   |  |
|---|--|
| A | Main cabinet   |
| B | Big extension cabinet  |
| C | Levelling mat (height: 10 mm) or pedestal (optional – height: 80 mm) |

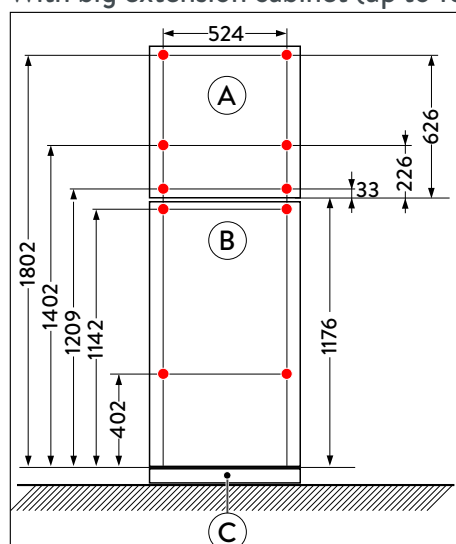

For storage systems consisting of main and big extension cabinet:

- ▶ Drill the holes shown in red in figure on the left.
- ▶ Note that the storage system must be placed on the levelling mat or the pedestal (C).

#### Without extension cabinet

If the storage system is used without extension cabinet it is a good idea to observe the dimensions provided in one of the two figures above. That way no new holes need to be drilled if the storage system is extended at a later time.

## 5.6.4 Mounting the storage system

### 1 Mount the extension cabinet

Figure 13:  
Screwing on the extension cabinet

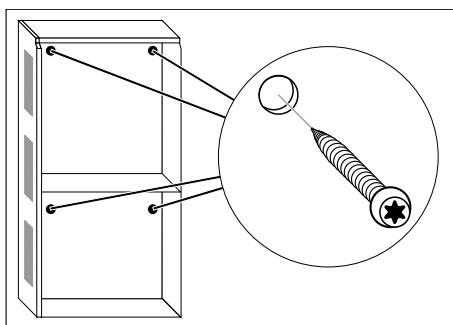

► Mount the extension cabinet (optional) on the wall using suitable screws and dowels (see 5.6.1 – pg. 22).

### 2 Apply the screws

There are keyhole attachments on the rear of the main cabinet. The main cabinet is mounted using these attachments.

Figure 14:  
Distance between screw head and wall

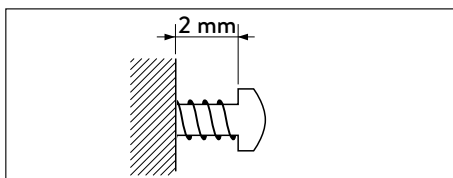

► Apply suitable screws and anchors (see 5.6.1 – pg. 22) to the previously drilled holes.

The screw should not be completely screwed in. The screw head should protrude from the wall by approx. 2 mm (see above figure).

### 3 Remove the blind caps

Figure 15: Remove the blind caps

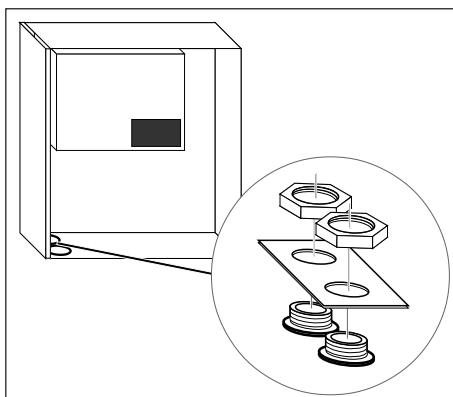

► Remove the blind caps. The blind caps are located at the bottom of the main cabinet.

### 4 Mount the main cabinet

Figure 16:  
Mounting the main cabinet

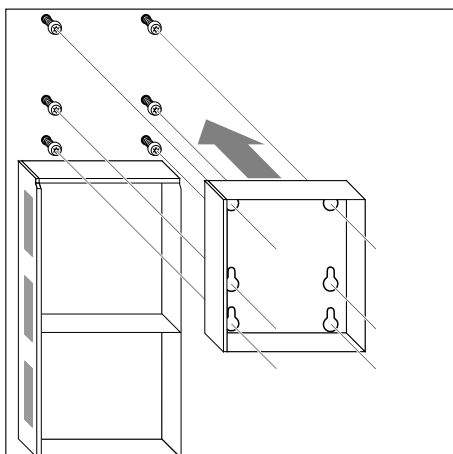

► Hang the main cabinet on the previously mounted screws.



## 5 Tighten the screws

Figure 17:  
Tightening the screws on the main cabinet

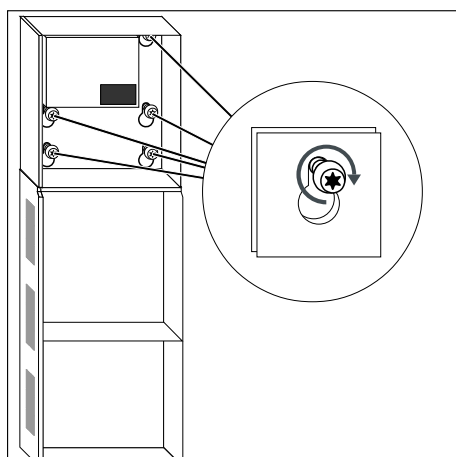

► Tighten the five screws.

## 6 Connect the housing

Figure 18:  
Connecting the housing

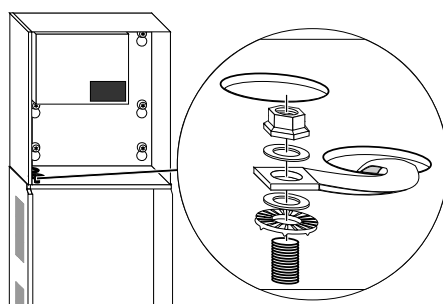

An earth conductor is already connected in the extension cabinet.

► Connect the other end of the earth conductor to the earth bolt in the main cabinet.

## 6 Electrical connection

---

### **DANGER**

#### **Danger to life due to electrocution!**

The following points must be observed when carrying out electrical work on the storage system or on the electrical distributor:

- ▶ Switch off the storage system.
  - ▶ Disconnect the relevant electrical circuits.
  - ▶ Secure against anyone switching on the device again.
  - ▶ Check that the device is disconnected from the power supply.
  - ▶ Only authorised electricians are permitted to carry out electrical work.
- 

### **DANGER**

#### **Touch voltage in the event of a fault**

Danger to life due to electrocution!

- ▶ Install residual current devices (RCDs) upstream of the storage system.

The rated differential current of the residual current device (RCD) must be 30 mA. The type of RCD used must be adapted to suit on-site conditions. If no special type is required, a type A residual current device (RCD) can be used.

---

### **Notice**

#### **Observe the maximum line lengths.**

None of the lines connected to the storage system (electrical power, Ethernet line, Modbus line, other data lines, etc.) are allowed to exceed a maximum length of 30 m.

---

## 6.1 Working on the electrical distributor

### 6.1.1 Placing components in the distributor

Several components must be placed in the electrical distributor for the electrical connection of the storage system. Approx. 25 cm of free space on a mounting rail is required for placing the components.

► Place the following components in the electrical distributor:

Figure 19:  
Components to be placed in the distributor

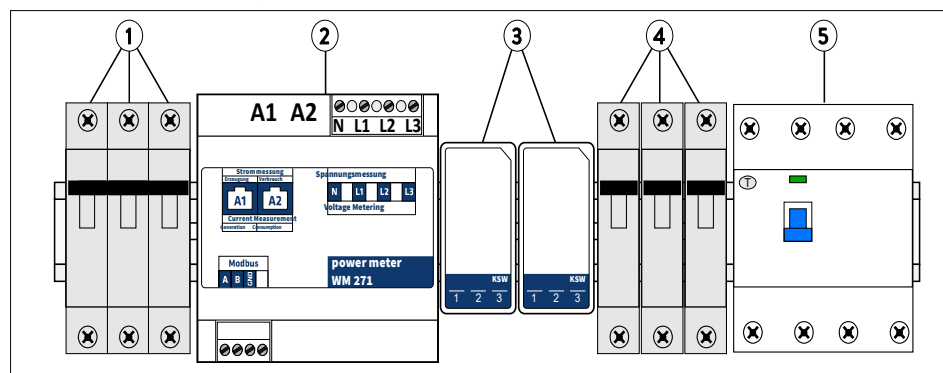

- |   |   |
|---|---|
| 1 | Miniature circuit breaker B16 (not included in scope of delivery)         |
| 2 | WM 271 power meter  |
| 3 | Transformer interfaces  |
| 4 | B6 miniature circuit breaker  |
| 5 | Residual current device (RCD) – 30 mA (not included in scope of delivery) |

#### Explanations for the components:

- The miniature circuit breaker (1) protects the connection line to the storage system.
- The power meter (2) and the transformer interfaces (3) are used to measure the consumption and generation of power in the building.
- The miniature circuit breaker (4) protects the line that is connected to the input for measuring the voltage of the power meter (2).
- The RCD (5) protects against high touch voltage in the event of a fault.

### 6.1.2 Wiring components in the electrical distributor

► Wire the components previously placed in the electrical distributor like it is shown on the following pages.

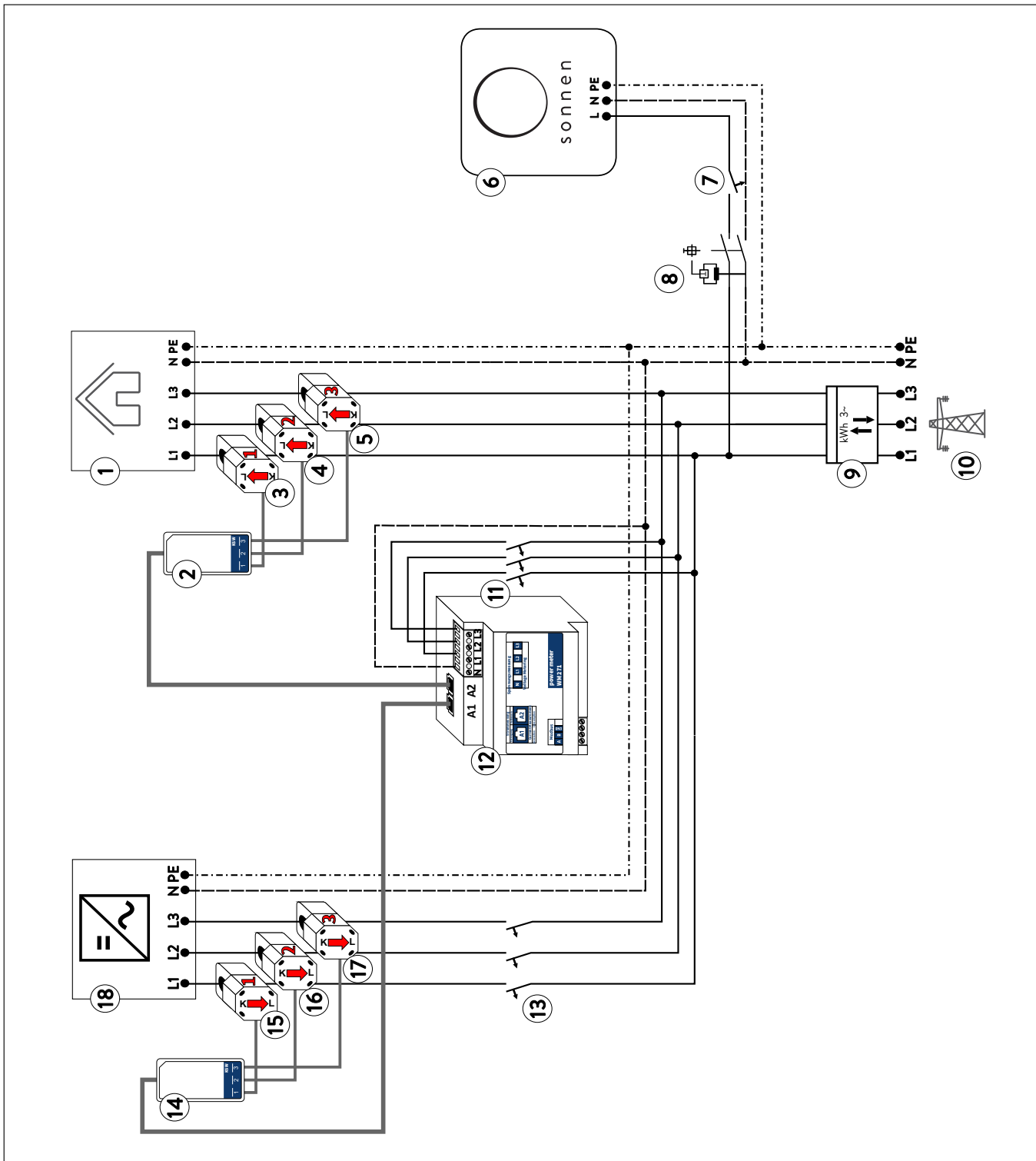

Figure 20: Circuit diagram overview – electrical connection at three-phase mains

1 Consumers in building	7 B16 miniature circuit breaker	13 PV inverter miniature circuit breaker
2 Transformer interface for consumption (A2)	8 RCD – 30 mA	14 Transformer interface for generation (A1)
3 Current transformer for consumption – L1	9 Bidirectional counter	15 Current transformer for production – L1
4 Current transformer for consumption – L2	10 Public electrical mains	16 Current transformer for production – L2
5 Current transformer for consumption – L3	11 B6 miniature circuit breaker	17 Current transformer for production – L3
6 Storage system	12 WM 271 power meter	18 PV inverter

The following points must be observed when connecting the power meters:

Figure 21:

Power meter components

1	A1 – input for generation
2	A2 – input for consumption
3	Voltage measurement terminal strip
4	Power meter
5	Transformer interface for consumption
6	Clamp-on current transformer for consumption – L1
7	Clamp-on current transformer for consumption – L2
8	Clamp-on current transformer for consumption – L3
9	Clamp-on current transformer for generation – L1
10	Clamp-on current transformer for generation – L2
11	Clamp-on current transformer for generation – L3
12	Transformer interface for generation
13	Modbus terminal strip

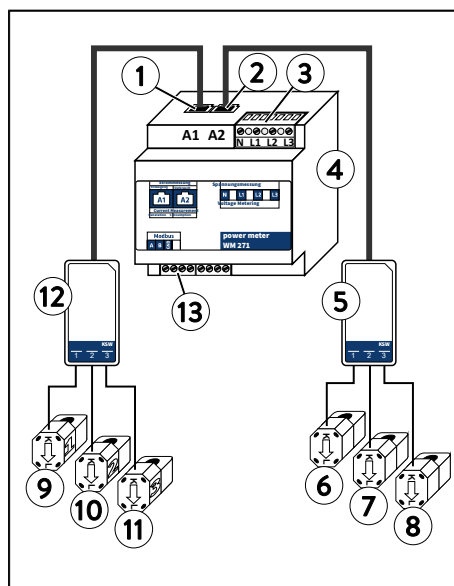

- Never confuse inputs A1 and A2.
- The lines connected to the voltage measurement terminal strip (3) must be protected by the supplied miniature circuit breakers (B6). The supplied miniature circuit breakers do not have to be installed if the lines are already protected by existing circuit breakers.

Figure 22:

Correct (left) and incorrect (right) energy flow direction

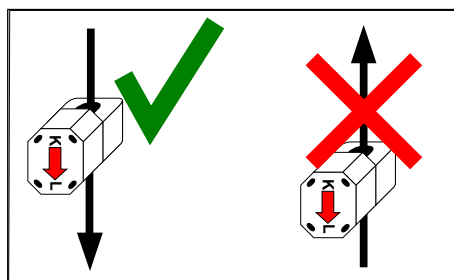

- The clamp-on current transformers are clamped across the affected lines. The energy flow direction of the clamp-on current transformer must be observed.

The energy flow in the line must run from K to L.

Figure 23:

Connecting the clamp-on current transformers for three-phase (left) and one-phase generators (right)

1	Clamp-on current transformer for generation L1
2	Clamp-on current transformer for generation L2
3	Clamp-on current transformer for generation L3
4	Transformer interface for generation
5	PV inverter or generator

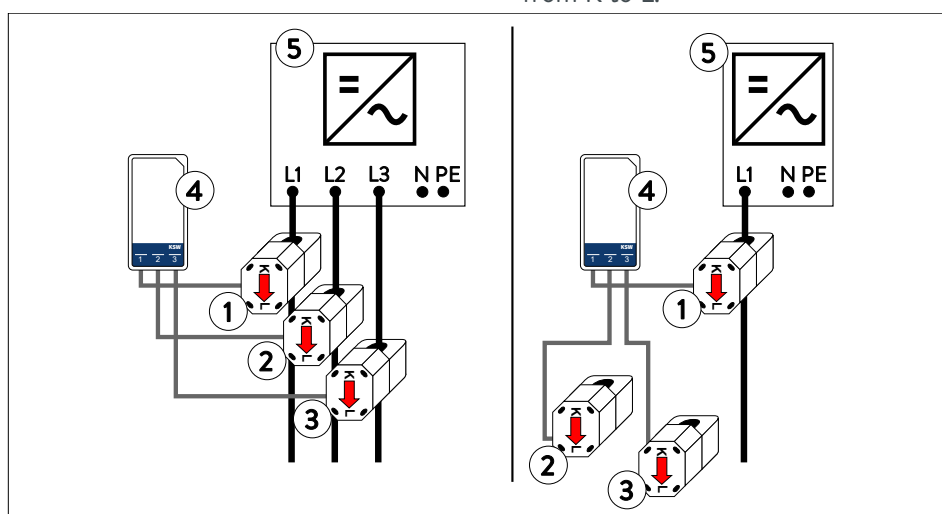

- In the case of a one-phase PV inverter or a single-phase mains, only the clamp-on current transformer for the phase in question is connected. The other two clamp-on current transformers must not be connected.

Figure 24:

Connecting the clamp-on current transformers – incorrect (top) and correct (bottom)

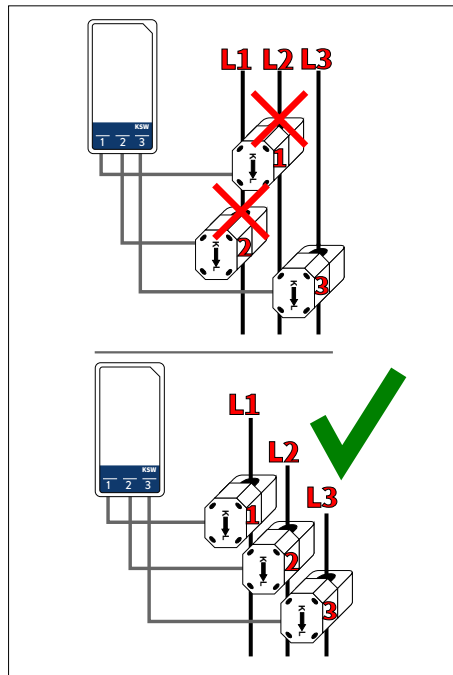

- **Do not confuse the phases.**

Power measurement only works if the current and voltage of the same phase are measured.

Example: clamp-on current

transformer L1 (marked with number 1) must be connected to phase L1.

This phase L1 must also be connected to terminal L1 of the voltage measurement terminal strip. Only

then can the correct power for phase L1 be determined.

## 6.2 Connecting the Ethernet cable

- ▶ Use a patch cable with the following properties as the Ethernet cable:
  - Patch cable is Cat 5 e
  - Patch cable is shielded
  - One end of the patch cable has an angled male connector (1) so that the cover can be completely closed.
- ▶ Connect the patch cable (2) to the Ethernet port (XETH) of the main cabinet.
- ▶ Connect the other end of the Ethernet cable to the router of the home network (3).

Figure 25:  
Connecting the Ethernet line to the top  
of the main cabinet

1	Angled connector
2	Patch cable (not included in scope of delivery)
3	Home network router
XETH	Ethernet port

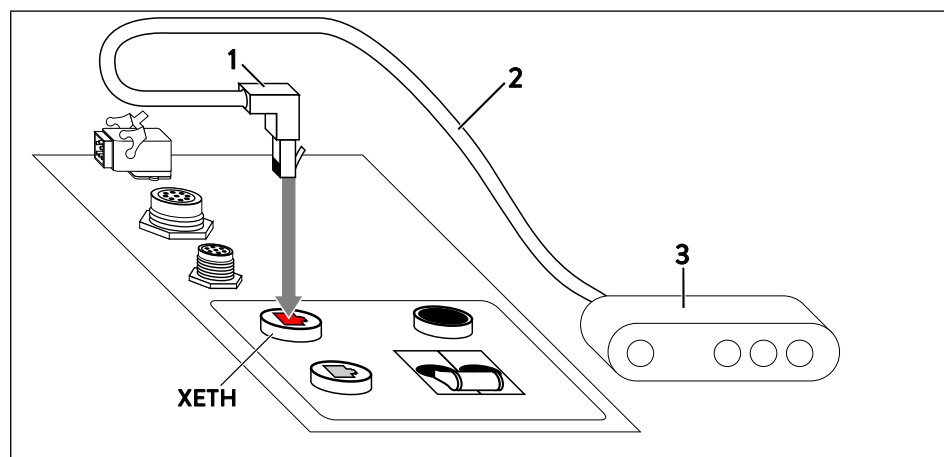

Upon commissioning, the storage system automatically establishes the connection to the internet once the patch cable has been correctly connected.

If the connection to the internet is not automatically established after commissioning:

- ▶ Follow the instruction in section 8 (S. 59).

## 6.3 Connecting the Modbus cable

Measurement data is transmitted from the power meter to the storage system using the Modbus line.

- ▶ Use a patch cable with the following properties as the Modbus cable:
  - Patch cable is Cat 5 e
  - Patch cable is shielded
  - One end of the patch cable has an angled male connector (1) so that the cover can be completely closed.
- ▶ Connect the patch cable (1) as shown in the following figure.

Figure 26:

Connecting the Modbus line

1	Angled male connector
2	Patch cable (not included in scope of delivery)
3	Power meter
4	Modbus terminal strip
5	Modbus line
6	RJ45 coupling
7	Ports on top of the main cabinet
XMOD Modbus port	

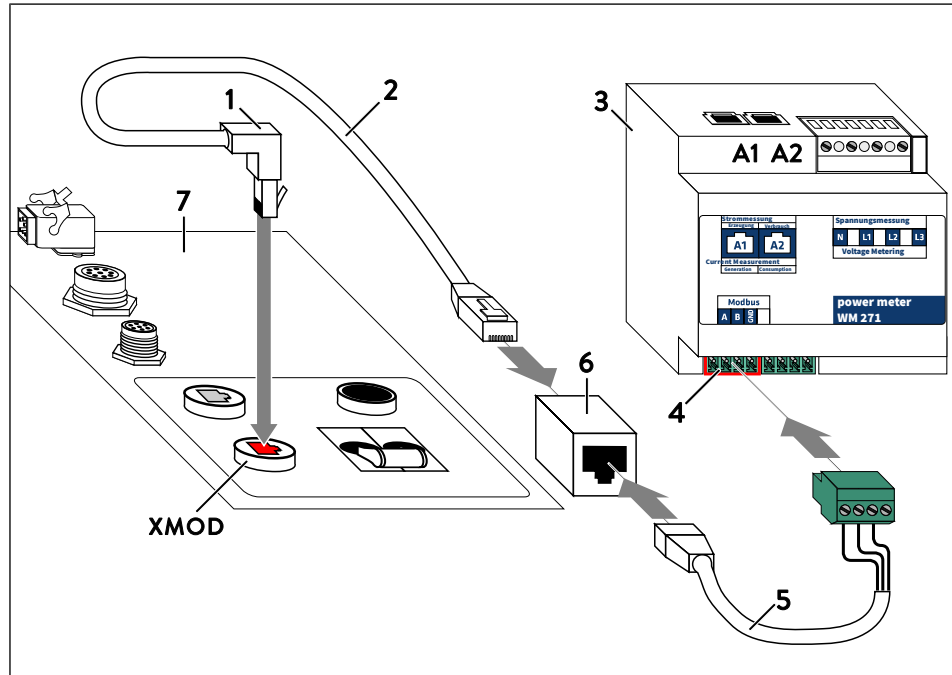



## 6.4 Connecting the mains line

**! DANGER**

### Danger to life due to electrocution!

The following points must be observed when carrying out electrical work on the storage system or on the electrical distributor:

- ▶ Switch off the storage system.
- ▶ Disconnect the relevant electrical circuits.
- ▶ Secure against anyone switching on the device again.
- ▶ Check that the device is disconnected from the power supply.
- ▶ Only authorised electricians are permitted to carry out electrical work.

▶ Connect the AC line as shown in the figure below.

Ensure that the stickers (2 and 3) face upwards.

▶ Close the lock (4).

Figure 27: Connecting the mains line

1	Sticker
2	Sticker
3	Lock
4	Mains line plug
XAC	Mains connection socket

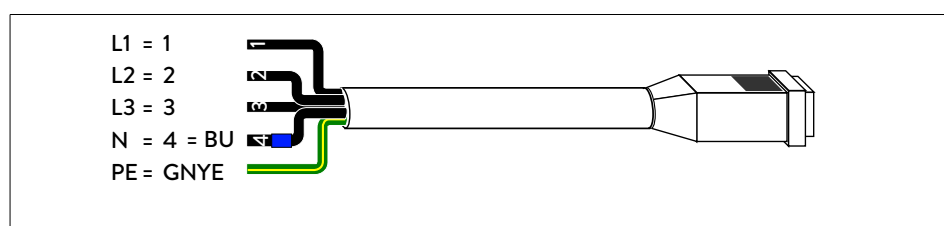
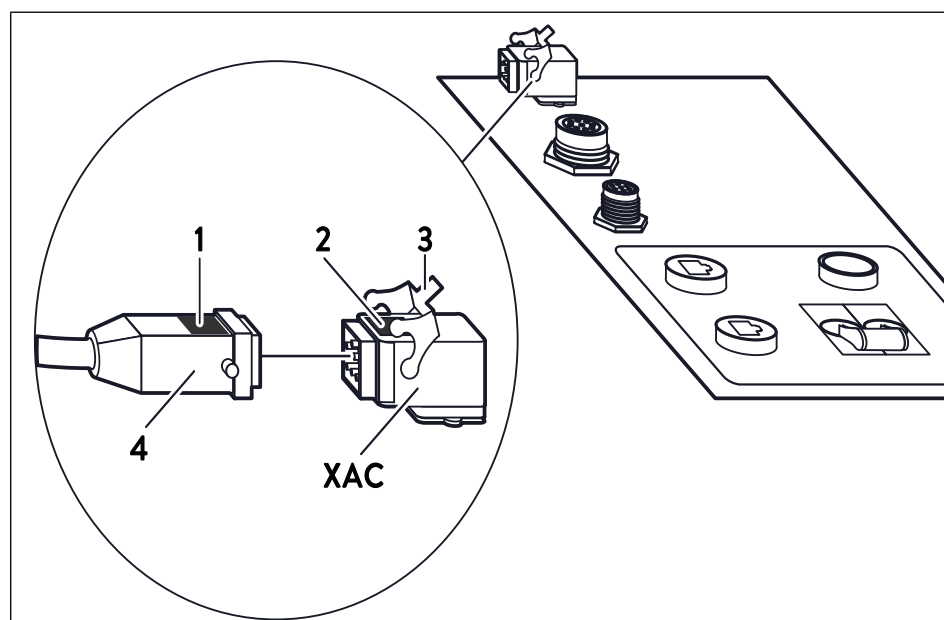

Figure 28: Numbered mains line

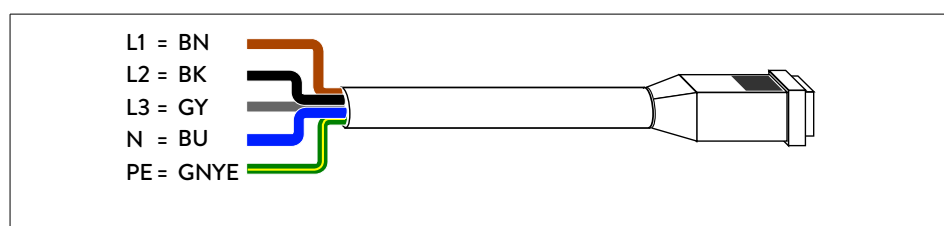

Figure 29: Color-coded mains line

 **DANGER**

## 6.5 Using digital outputs

---

### Electrical work on the storage system and electrical distributor

Danger to life due to electrocution!

- ▶ Switch off the storage system.
  - ▶ Disconnect the relevant electrical circuits.
  - ▶ Secure against anyone switching on the device again.
  - ▶ Check that the device is disconnected from the power supply.
  - ▶ Only authorised electricians are permitted to carry out electrical work.
- 



The wiring configurations described in this section are examples only and serve as a guide for electricians working on the system.

The wiring configurations are not universal. The electricians working on the system are responsible for the correct wiring of the system.

In some cases, the permission of the distribution grid operator or power supply company may be required.

---

### 6.5.1 Connecting the signal line

Digital outputs (XDO) are located on top of the storage system. These can be used to control external devices. The digital signals are transmitted via the signal line (2). We recommend connecting the signal line to a terminal strip (3). The individual wires of the signal line coming from the terminal strip can then be distributed to the corresponding downstream external components.

The white wire of the signal line (2) represents the earth (GND). If more than one digital output is used, multiple lines must be connected to the earth. For this reason we recommend installing multiple terminals which are connected via a bridge (4) to the earth (GND).

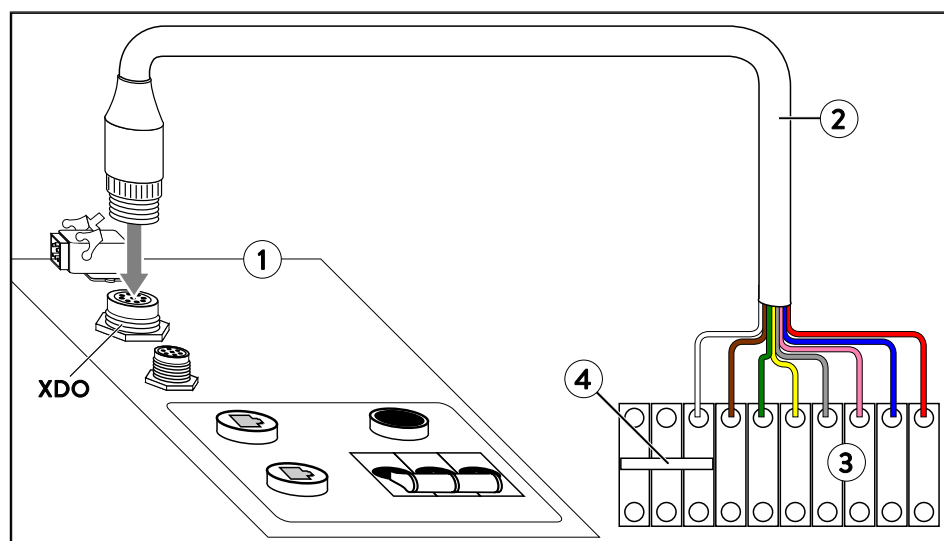

Figure 30: Connecting the signal line for digital outputs

1	Signal line
2	Signal line
3	Terminal strip
4	Bridge for connecting terminals
XDO	Digital outputs

Wire colour	Wire cross-section	Voltage	Max. Amperage	Function
white	0,25 qmm	0 VDC	350 mA	Earth (GND)
brown	0,25 qmm	24 VDC	50 mA	DO self-consumption switch
green	0,25 qmm	24 VDC	50 mA	DO PV reduction 1
yellow	0,25 qmm	24 VDC	50 mA	DO PV reduction 2
grey	0,25 qmm	24 VDC	50 mA	DO min/max SoC
blue-red	0,25 qmm	24 VDC	50 mA	DI CHP
grey-pink	0,25 qmm	24 VDC	50 mA	Supply voltage 24 V DC

► Connect the signal line as shown in Figure 30.

## 6.5.2 Using the 'PV reduction' digital outputs

Using the PV reduction digital outputs – PV reduction 1 and 2 – is a good idea if the feed-in power of the PV system must not exceed a fixed value (feed-in limit).

The PV reduction digital outputs can be used to automatically control the output power of the PV inverter so that the feed-in power does not exceed the required value in a 10-minute average interval.

The digital outputs cannot be used directly. Additional relays are required, which are not included in the scope of delivery.

Figure 31:  
PV Reduction

1	Signal line
2	Earth (GND)
3	DO PV reduction 1
4	DO PV reduction 2
5	PV inverter with suitable interface for power control
K71	External relay (not included in scope of delivery)
K72	External relay (not included in scope of delivery)

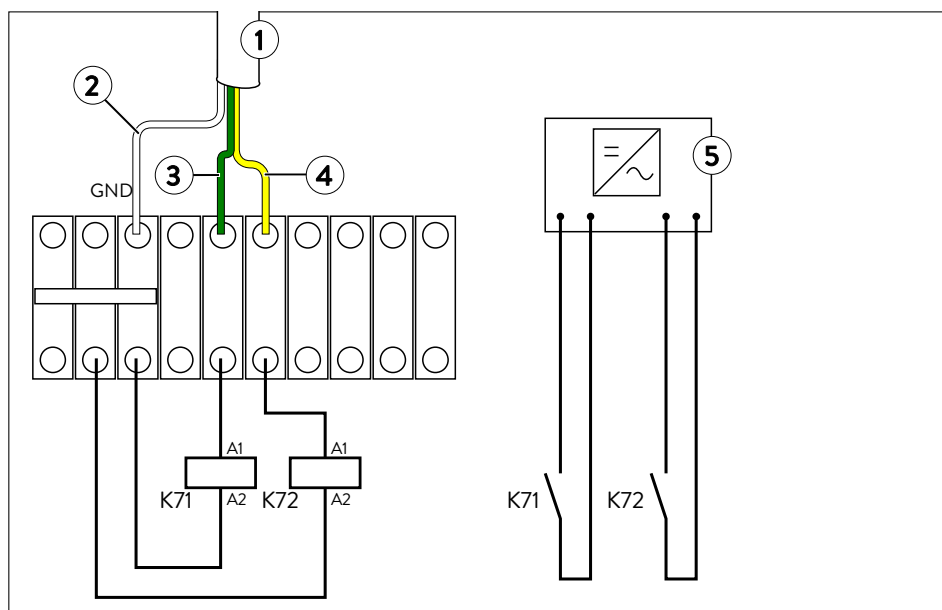

Level	K71	K72
0		
1		
2		
3		

Tabelle 5: Make contact positions of K71 and K72 relays depending on activated level

### Function

Relays K71 and K72 are connected to the green (PV reduction 1) and yellow (PV reduction 2) wires, respectively. If PV reduction 1 is activated (24 V DC applied to the green wire), K71 energises and the K71 make contact closes. K72 energises as soon as PV reduction 2 is activated (24 V DC applied to the yellow wire).

PV reductions 1 and 2 are activated/deactivated automatically by the storage system depending on the current feed-in power. If the feed-in power is within the permissible range, PV reduction 1 and PV reduction 2 are deactivated. K71 and K72 are not energised. This corresponds to level 0. As soon as a power reduction is required, K71 and K72 are energised according to the data provided in the left-hand table. If level 1 does not achieve the desired effect, for example, then level 2 is activated, and so forth.

## Notice

### Wiring the 'PV reduction' digital outputs

#### Overvoltage when switching off electromagnetic relays

Damage to components!

Only use electromagnetic relays with a protective circuit (e.g. with a free-wheeling diode) or semiconductor relays.

Tools:

- 2 relays<sup>1</sup> with the following properties:
  - Coil voltage: 24 VDC
  - Max. control current: 50 mA
  - 1 make contact

Prerequisite :

✓ The PV inverter has a suitable interface for power control (e.g. an interface for a ripple control receiver).

▶ Wire the 'PV reduction' digital outputs as shown in Figure 31 (pg. 36).

▶ Set the following values on the PV inverter:

Level	Max. active power
0	100 %
1	Feed-in limit of PV system in %
2	Half of feed-in limit of PV system in %
3	0%

The values for levels 1 and 2 depend on the individual feed-in limit of the PV system in question. If feed-in power for the PV system is limited to 50% of the nominal power, for example, the following values should be set: Level 1: 50%, level 2: 25%.

<sup>1</sup> We recommend using the following relay:

Manufacturer: Finder | item no.: 483170240050 | item designation: 48 Series – Modular interface

### 6.5.3 Using the 'self-consumption switch' digital output

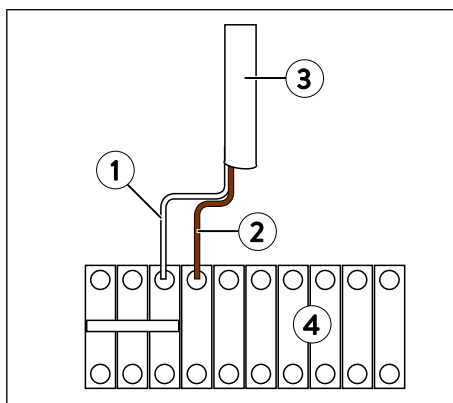

Figure 32: self-consumption switch

1	Earth (GND)
2	Self-consumption switch
3	Signal line for digital outputs
4	Terminal strip

#### Function

The storage system software can be used to set a switch-on threshold and a minimum switch-on duration.

If the generation surplus (= generation – consumption – charging of the storage system) exceeds the set switch-on threshold, the self-consumption switch is activated. The self-consumption switch then remains active for the set minimum switch-on duration.

#### Configuring software settings

The switching behaviour of the self-consumption switch can be configured using the commissioning wizard (see section 7.3 – pg. 56).

- Adjust the switch-on threshold and minimum switch-on duration to suit the consumers that are activated using the self-consumption switch.

#### Application example

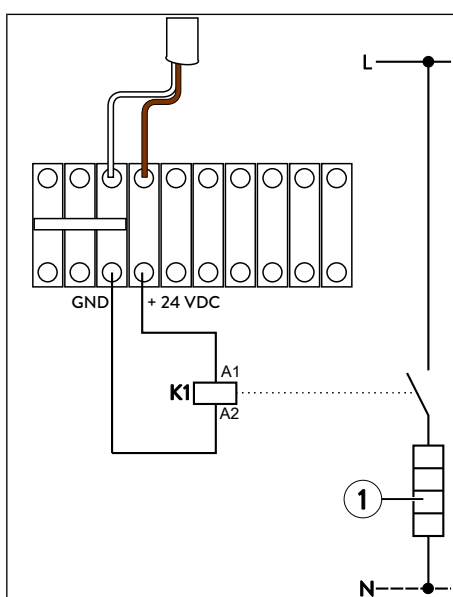

Figure 33: Activating/deactivating a thermal resistor

1	Heating element
K1 <sub>ex</sub>	External contactor (not included in scope of delivery)

As an example, a heating element (1) can be activated/deactivated using the self-consumption switch.

In this case it is a good idea to set the nominal power of the heating element as the switch-on threshold.

Note that suitable safety measures must be in place to prevent the heating medium from overheating.

### 6.5.4 Using the 'min/max SoC' digital output

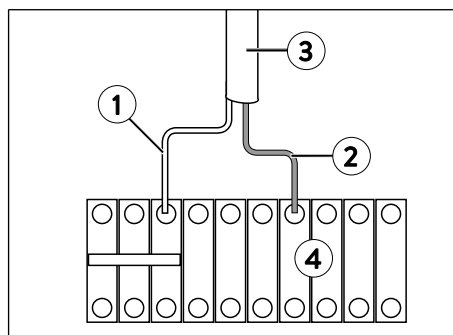

Figure 34: min/max SoC digital output

1	Earth (GND)
2	DO min/max SoC
3	Signal line for digital outputs
4	Terminal strip

#### Function

The storage system software can be used to set a minimum state of charge (min SoC) and a maximum state of charge (max SoC).

If the state of charge of the storage system drops below the min SoC value, the digital output is activated. The digital output is only then deactivated when the state of charge exceeds the max SoC value.

#### Configuring software settings

The switching behaviour of the min/max SoC digital output can be configured using the commissioning wizard (see section 7.3 – pg. 56).

- Set suitable values for the min SoC and max SoC variables.

#### Application example

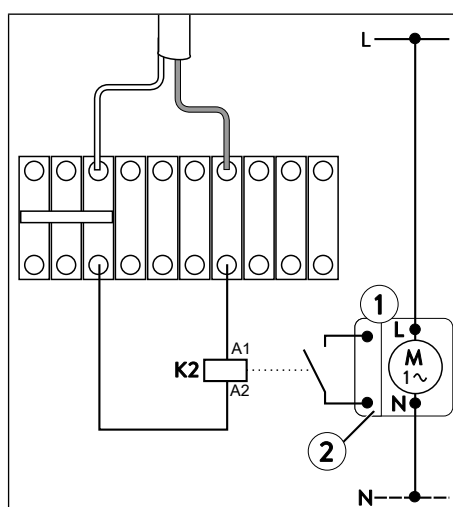

Figure 35: Activating/deactivating a CHP unit

1	CHP
2	Contact for activating CHP
K2	External relay (not included in scope of delivery)

As an example, a CHP unit (1) can be activated/deactivated using the min/max SoC digital output.

The CHP unit must be available via a suitable interface (2) for activation/deactivation.

In this example, the generation surplus produced by the CHP unit can be used to charge the storage system. The power output of the CHP unit must be recorded for this.



## 6.6 Using accessories

---

### Electrical work on the storage system and electrical distributor

Danger to life due to electrocution!

- ▶ Switch off the storage system.
  - ▶ Disconnect the relevant electrical circuits.
  - ▶ Secure against anyone switching on the device again.
  - ▶ Check that the device is disconnected from the power supply.
  - ▶ Only authorised electricians are permitted to carry out electrical work.
- 

### 6.6.1 Using 'heat pump control'

---



Permission from the responsible distribution grid operator or power supply company must be obtained before the heat pump control is installed in the electrical distributor.

---

The heat pump control can be used when the heat pump is billed using a separate energy meter. In this case the heat pump is located in a separate current path (heat pump current path) that is not recorded by the consumption measurement of the power meter.

Using the heat pump control, the heat pump can be switched to the current path (power meter current path) for which consumption is recorded by the power meter. If this happens, the consumption of the heat pump is measured and included in the storage system controls.



## Function

If the self-consumption switch is activated, K230, K30 and then Q31 energise (see Figure 36 – pg. 42). The heat pump current path is interrupted.

K40 energises five seconds after the self-consumption switch is activated. Then K41 energises. The power meter current path is closed.

The auxiliary make contact 23/24 for Q31 can be used to activate the heat pump. This requires a suitable interface (6) for the heat pump.

When the self-consumption switch is deactivated, K40 de-energises immediately. The power meter current path is interrupted.

K30 de-energises five seconds after the self-consumption switch is deactivated. Then Q31 de-energises. The heat pump current path is closed.

## Wiring the heat pump control

- ▶ Wire the heat pump control as shown in Figure 36 (pg. 42).
- ▶ Ensure that a de-energising delay (RV) of 5 seconds is set at relay K30.
- ▶ Ensure that an energising delay (AV) of 5 seconds is set at relay K40.

## Configuring software settings

The switching behaviour of the self-consumption switch can be configured using the commissioning wizard (see Section 7.3 – pg. 56).

- ▶ Set suitable values for the switching behaviour of the self-consumption switch. The switch-on threshold and the minimum switch-on duration should be set so that the current paths are not switched back and forth too frequently.

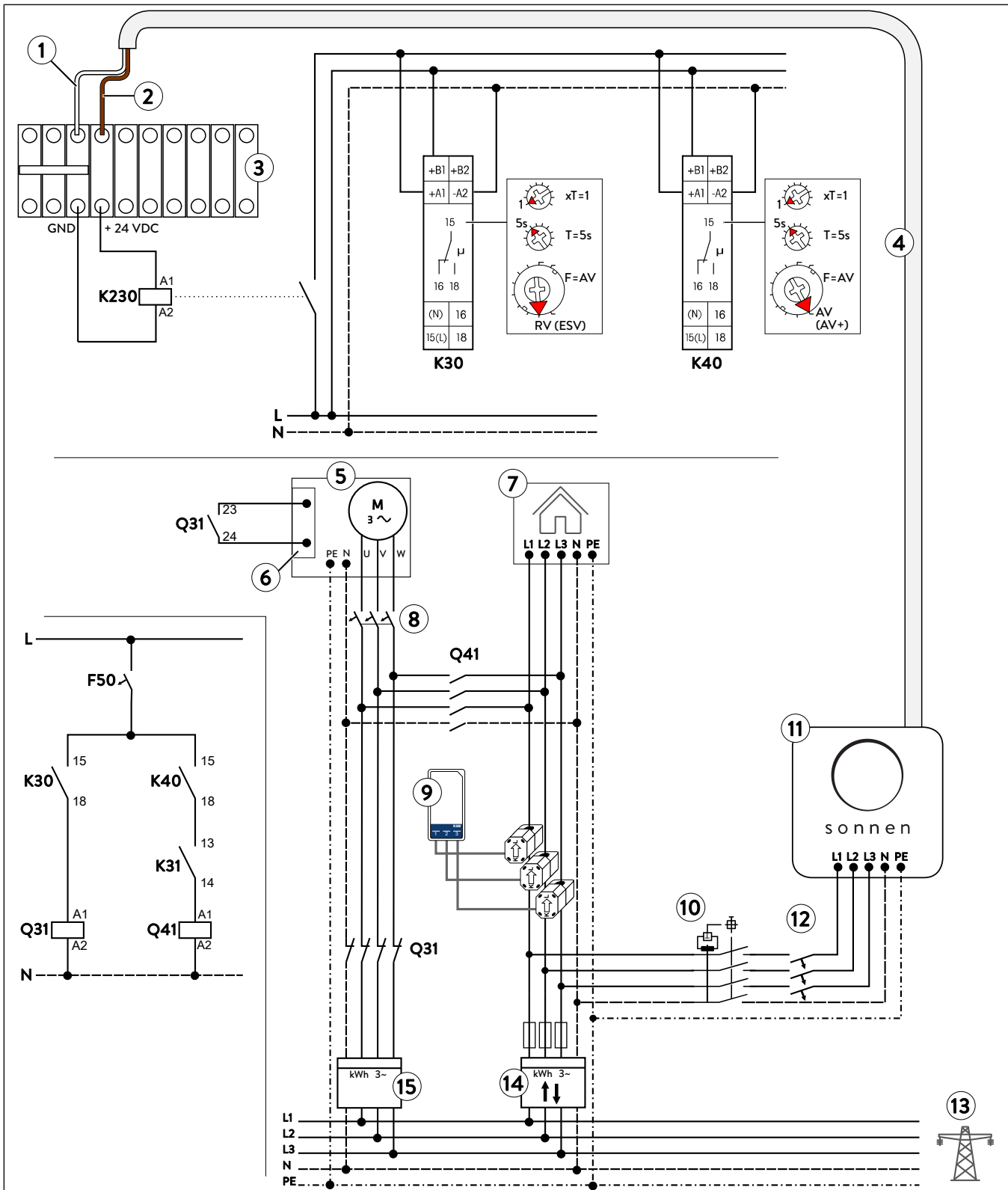

Figure 36: Wiring the heat pump control

1 Earth (GND)	6 Contact for activating the heat pump	11 Storage system
2 DO self-consumption switch	7 Consumers in building	12 Miniature circuit breaker
3 Terminal strip	8 Miniature circuit breaker	13 Public electrical mains
4 Signal line for digital outputs	9 Power meter – transformer interface for consumption	14 Bidirectional counter
5 Heat pump	10 Residual current device (required in TT network)	15 Heat pump energy meter

## 6.7 Installing the battery modules

### **WARNING**

#### Risk of burns!

Very high short-circuit currents are possible.

The following must be observed when working with the battery modules:

The battery module is activated when the fuse connector is plugged in. The voltage runs between the plus and minus contacts of the battery module (nominal voltage of battery modules: 51.2 V DC). The battery module is deactivated when the fuse connector is unplugged. No voltage runs between the plus and minus contacts of the battery module. If all interconnected battery modules are deactivated, it is safe to work on a battery module.

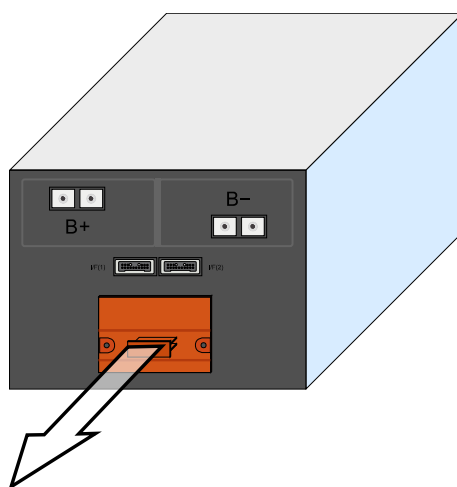

When working on the DC circuit:

- ▶ Set aside metal jewellery.
- ▶ Switch off the storage system.
- ▶ Switch off the series fuse.
- ▶ Remove the orange fuse connectors on all battery modules.

### **Notice**

#### Damage to battery modules due to short circuit!

If a short circuit occurs when installing the battery modules despite great care to avoid this, proceed as follows:

- ▶ Do not install the affected battery modules under any circumstance.
- ▶ Notify the service team.

## Notice

### 6.7.1 Measuring the battery module voltages

#### Damage to battery modules due to high compensating currents!

Differing battery module voltages lead to high compensating currents when the storage system is switched on.

► Measure the voltages between the internal plus and minus poles of all battery modules (see figure below) and note these down.

The battery modules are only allowed to be installed if the maximum deviation between the measured voltages is less than 1 V. If the deviation is greater than 1 V:

► Notify the service team.

Figure 37:

Measuring the battery module voltages

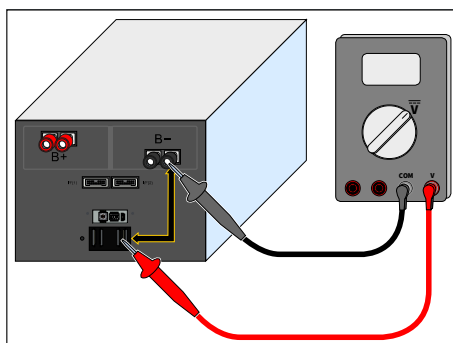

### 6.7.2 Numbering the battery modules

Figure 38:

Numbering the battery module

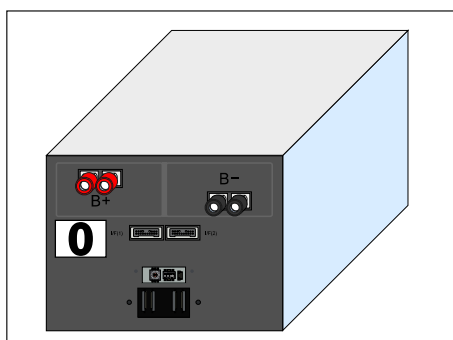

► Apply the supplied stickers to the modules.

The numbering begins with zero and continues in ascending order.

### 6.7.3 Defining the communication addresses

Figure 39:

Setting the communication addresses using the rotary switch

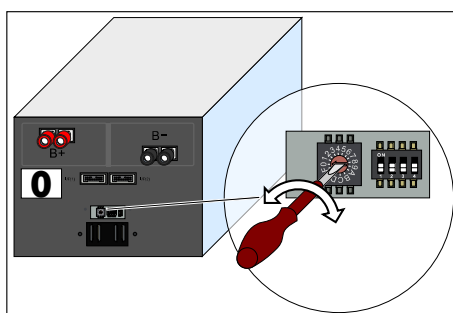

► Set the communication addresses for the battery modules using the rotary switch.

The communication address matches the number of the battery module.

### 6.7.4 Setting the termination switches

Figure 40:  
Setting the termination switch on the  
battery module with the highest number

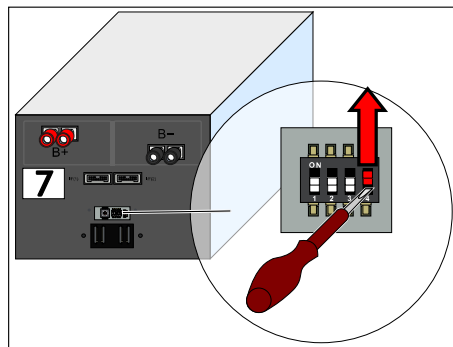

- ▶ Slide the termination switch (switch 4) of the battery module with the highest number<sup>2</sup> up (switch position *ON*).
- ▶ Ensure that the termination switches of all other battery modules are in switch position *OFF*.

### 6.7.5 Positioning the battery modules

Figure 41:  
Positioning the battery modules –  
without extension cabinet (left) and  
with extension cabinet (right)

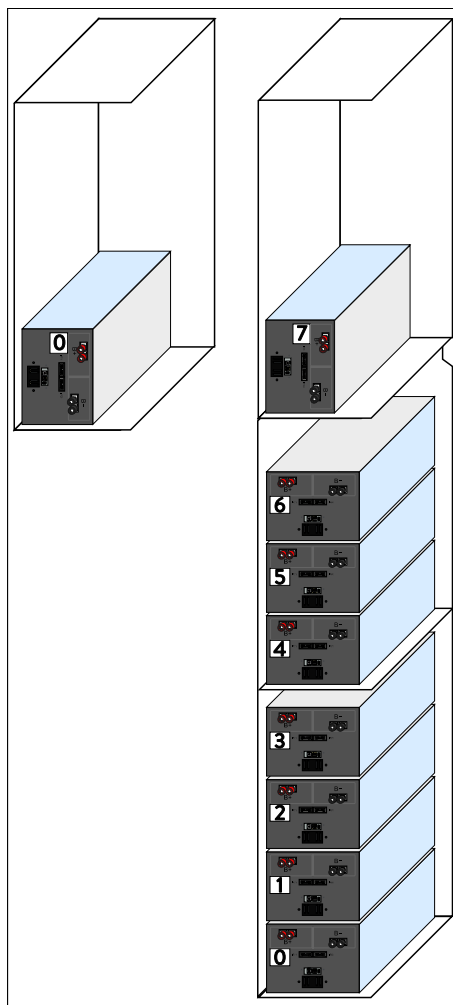

If **no** extension cabinet is used:

- ▶ Position the battery module as shown in the left part of the image.

If an extension cabinet is used:

- ▶ Position the battery modules as shown in the right part of the image.

<sup>2</sup> With a sonnenBatterie eco 8/2 this is battery module 0, with a sonnenBatterie eco 8/4 this is battery module 1, and so on... With a sonnenBatterie eco 8/16 this is battery module 7.

## ! WARNING

### 6.7.6 Connecting the DC lines

#### Risk of fire due to high contact resistances and short circuit!

Incorrectly connected DC lines can cause a short circuit and thus high heat generation. Improperly connected DC lines can also create high resistance at the point of contact. As very high currents flow through the DC circuit, this high contact resistance can lead to great loss of energy (electrical energy is converted into heat). This can have the following effects:

- Cable fire:

The area around the affected point of contact is heated above permissible temperatures. A fire breaks out and hazardous substances are released.

- Damage to the battery modules:

The high contact resistance generates various high battery module loads. Battery modules may be damaged or destroyed by this. Therefore, proceed as follows:

► Check all plug connections. Only red lines are allowed to be plugged into red sockets. Only black lines are allowed to be plugged into black sockets.

Figure 42:

Correctly connected (top) and incorrectly connected (bottom) DC line

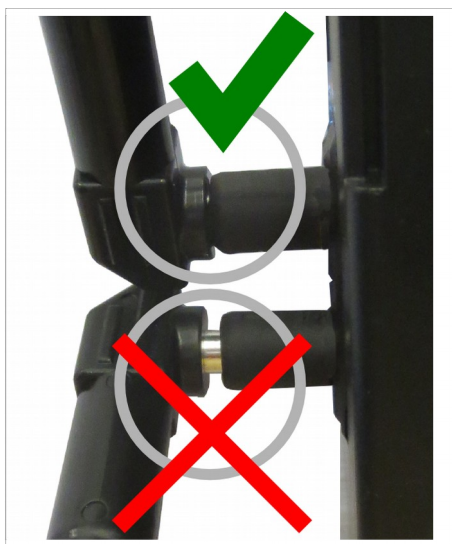

► Ensure that all DC lines are plugged into the sockets all the way.

## ! DANGER

#### Danger to life due to electrocution if DC lines are incorrectly connected!

Each battery module has a nominal voltage of 51.2 volts. The battery modules are connected in parallel using the supplied DC lines. The battery modules must never be connected in series, as this could result in life-threatening high voltages from the series connection. The high voltage can also lead to damage/destruction of components.

► Ensure that all battery modules are connected in parallel, i.e. all plus poles of the battery modules are connected together (red to red). Likewise, ensure that all minus poles of the battery modules are connected together (black to black).

If **no** extension cabinet is used:

- ▶ Connect the DC lines as shown in the figure on the right.

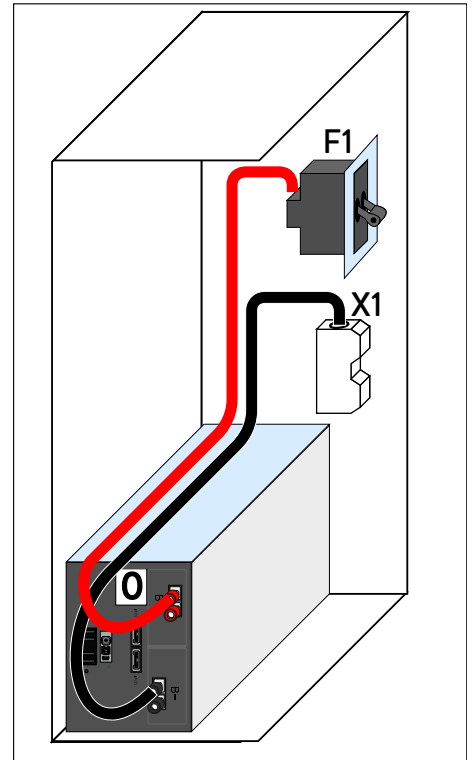

Figure 43: Connecting the DC lines on the sonnenBatterie eco 8/2 without extension cabinet

If an extension cabinet is used:

► Connect the DC lines as shown in the figure on the right.

Observe the following points:

- The plus line is connected from F1 to the plus pole of battery module 0.
- The minus line is connected from terminal X3 to the minus pole of the last battery module (with the highest number).

With a sonnenBatterie eco 8/2 this is battery module 0,  
 with a sonnenBatterie eco 8/4 this is battery module 1,  
 with a sonnenBatterie eco 8/6 this is battery module 2, and so on...  
 with a sonnenBatterie eco 8/16 this is battery module 7.

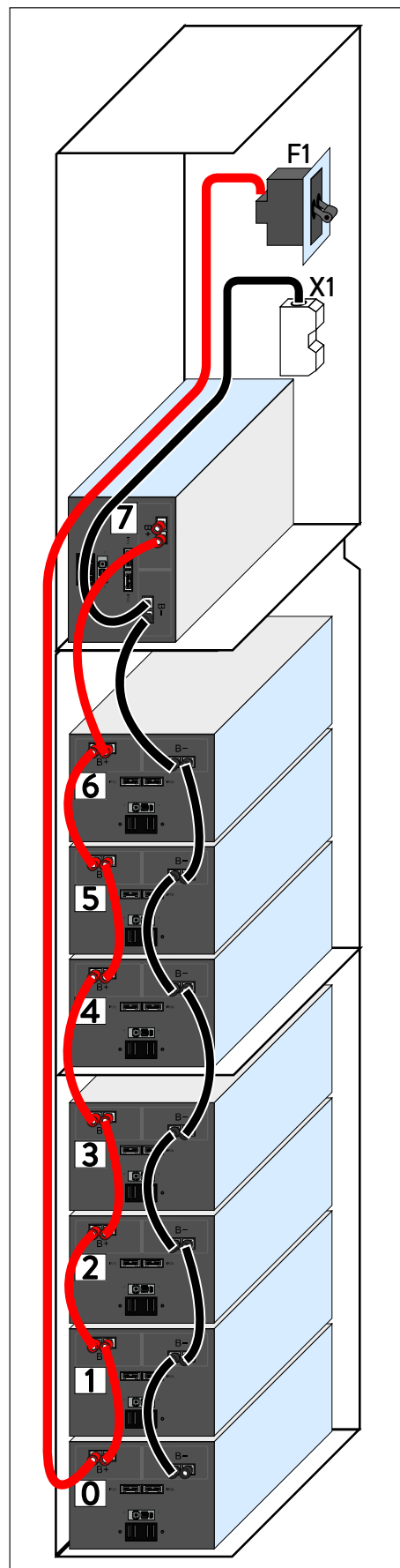

Figure 44: Connecting the DC lines on the sonnenBatterie eco 8/16



### 6.7.7 Connecting the BMS communication line

- ▶ Connect the BMS lines as shown in the following figures. Use the supplied BMS communication lines.

Figure 45:  
Connecting the BMS communication  
line on the sonnenBatterie eco 8/2

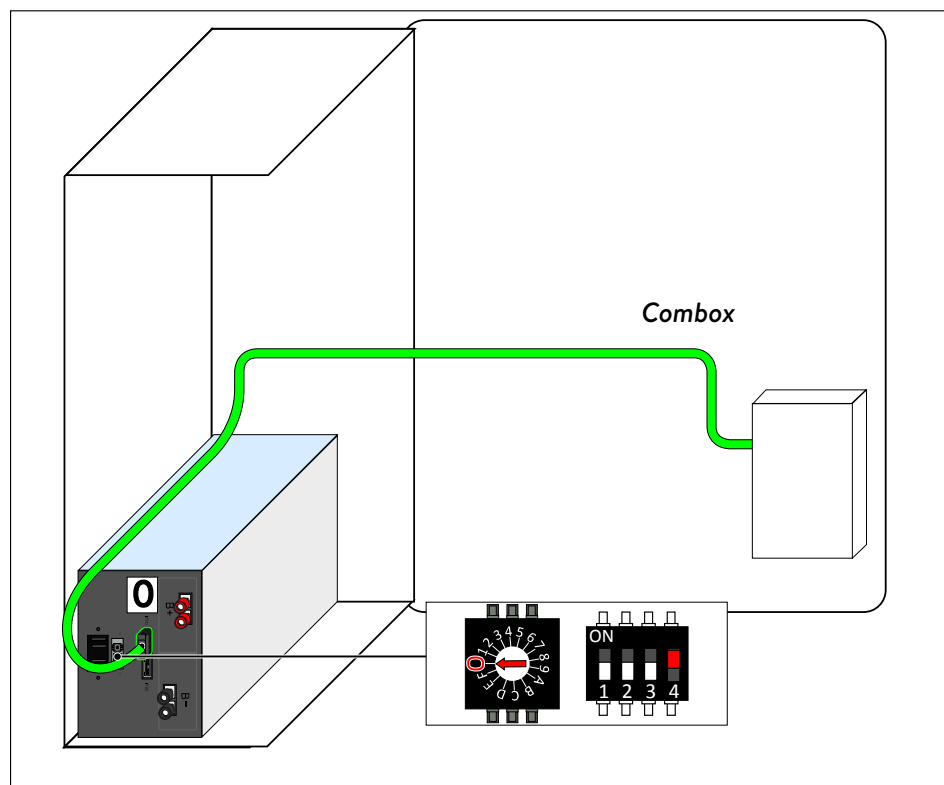
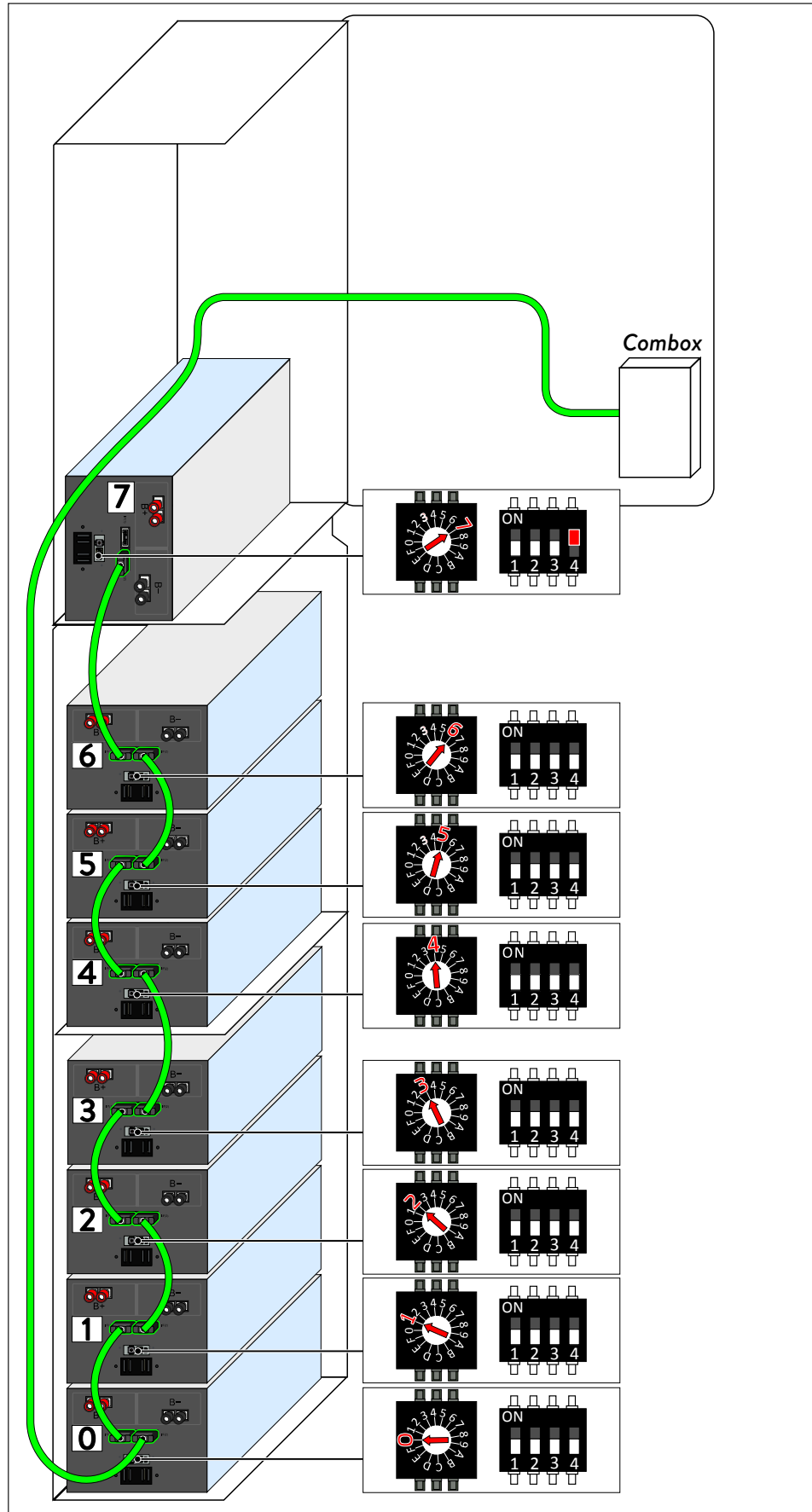

Figure 46:  
Connecting the BMS communication  
lines to 8 battery modules



### 6.7.8 Attaching the fuse plugs

Prerequisite:

✓ All DC lines and BMS communication lines are correctly connected to the battery modules.

▶ Attach the fuse plugs on all battery modules.

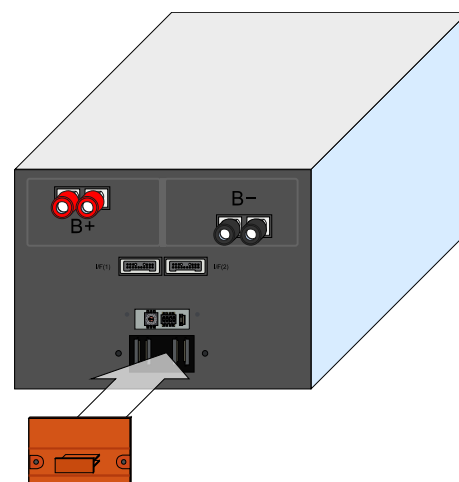

Figure 47: Attaching the fuse plugs

### 6.7.9 Entering the battery capacity/nominal power on the type plate

Tools:

- Permanent marker

▶ Mark off the correct battery capacity and nominal power on the type plate of the storage system.

The type plate is located on the outside of the storage system. The battery capacity and nominal power can be determined from the technical data (see page 12).

## 6.8 Mounting filter plates and cover

### 6.8.1 Mounting filter plates

The previously removed filter plates must be reinstalled.

Figure 48: Mounting the filter plates

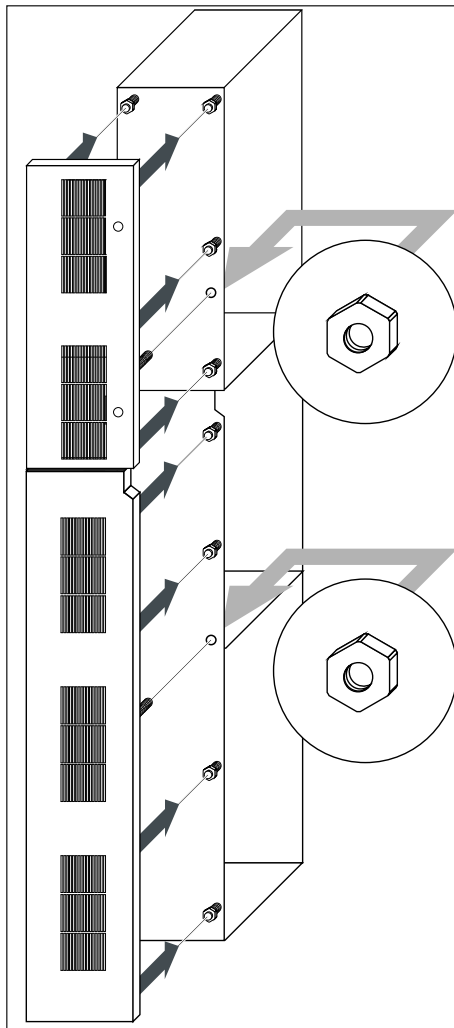

1. Mount the filter plate at the extension cabinet.
2. Slide the filter plate down, till it is in its end position.
3. Mount the filter plate at the main cabinet.
4. Slide the filter plate down, till it is in its end position.
5. Mount the nuts on the inside of the cabinets.

### 6.8.2 Connecting earthing conductor

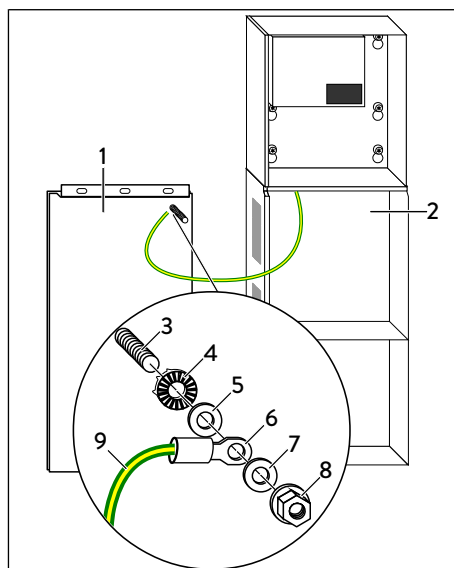

One earthing conductor (9) is connected to the optional extension cabinet.

- ▶ Connect the other end of the earthing conductor to the earth bolt (3). Take care of the positioning of the components (4) to (8).
- ▶ Tighten the locking nut (8) with a torque of 5 Nm.

Figure 49: Earthing wire between extension cabinet and cover

1	Cover
2	Extension cabinet
3	Earth bolt
4	Contact disc
5, 7	Washer
6	Cable lug
8	Locking nut
9	Earth conductor

### 6.8.3 Mounting cover

Figure 50: Mounting the cover of the extension cabinet

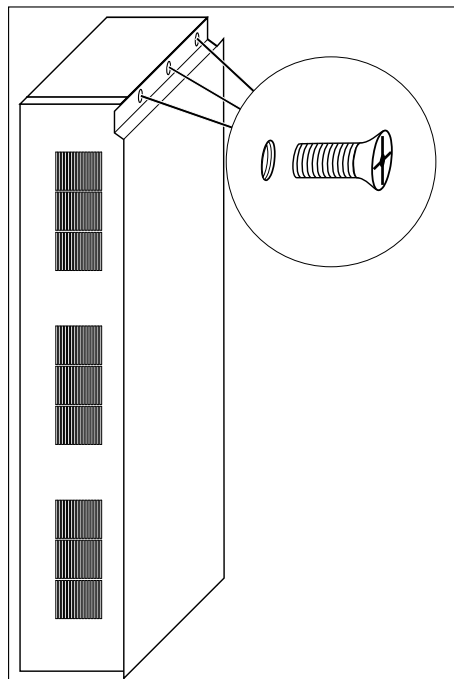

- ▶ Hook the cover into the front of the extension cabinet.
- ▶ Mount the cover with the three screws. Tighten the screws only slightly, making sure that the cover can still be moved.
- ▶ Close the door of the main cabinet and align the cover.
- ▶ Fully tighten the screws.

# 7 Commissioning

## 7.1 Initial commissioning

### 7.1.1 Commissioning checklist

► Check the following points during initial commissioning before switching on the system:

Table 6:  
Commissioning checklist

OK	Points to check
<input type="checkbox"/>	The installation location meets the requirements.
<input type="checkbox"/>	All DC lines are completely and correctly connected.
<input type="checkbox"/>	The Modbus line is correctly connected.
<input type="checkbox"/>	The Ethernet line is correctly connected.
<input type="checkbox"/>	The AC supply is correctly connected.
<input type="checkbox"/>	The AC line meets the requirements of all local and national guidelines for line dimensions.
<input type="checkbox"/>	The dimensions of the miniature circuit breaker installed in the AC line are correct.
<input type="checkbox"/>	A residual current device (RCD) has been correctly installed.

### 7.1.2 Commissioning report

- Complete the commissioning report in the appendix of this document in full.
- Make two copies of the commissioning report.
- Give the first copy to the operator.
- Send the second copy to sonnen GmbH within 5 working days.

## 7.2 Switching on the storage system

To switch on the storage system, the fuse switch F1 and switch S1 must be engaged in a specific order. F1 and S1 are located under the cover at the top side of the storage system.

### 7.2.1 Removing the cover

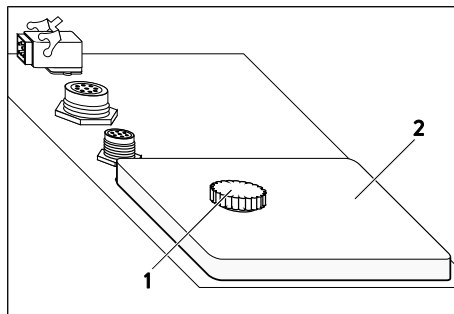

- ▶ Remove the knurled nut (1). To do this, rotate the knurled nut (1) counterclockwise.
- ▶ Remove the cover (2).

Abbildung 51: Removing the cover (2) at the top side of the storage system

### 7.2.2 Switching on the storage system

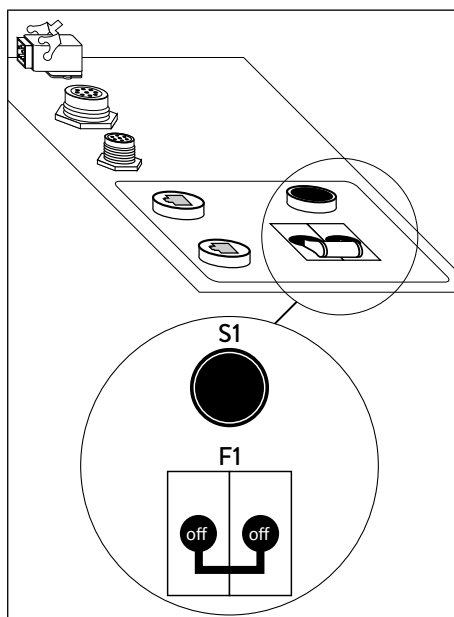

- 1 Press switch S1 and hold it down while the following steps are carried out.
- 2 Switch on fuse switch F1.
- 3 Keep switch S1 held down for at least another 5 seconds.
- 4 Release switch S1.

Abbildung 52: Fuse switch F1 and switch S1 at the top side of the storage system

The storage system then starts up and performs a self-test. Once the self-test is successful, the storage system is ready to operate.

- ▶ Mount the previously removed cover.

### 7.3 Running the commissioning wizard

With the help of the commissioning wizard the storage system can be configured. The operator as well as the authorised electrician have to enter some informations while the commissioning wizard is running.



---

The storage system is only ready for operation if the commissioning wizard is fully completed.

---



### 7.3.1 Establishing connection to storage system

► Connect the laptop (2) to the router of the home network.

The storage system must also be connected to the router of the home network.

Figure 53:  
Ethernet wiring

1	Ethernet line
2	Router of the home network
3	Ethernet line
4	Laptop
XETH	Ethernet port at the top side of the storage system

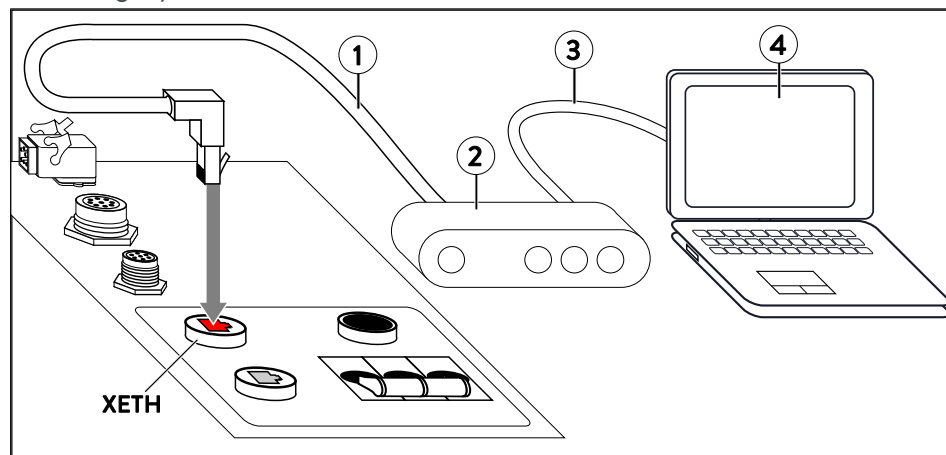

► Start a browser (e.g. Firefox, Chrome, Safari, ...) at your laptop.

► Enter the address *finde-meine.sonnenbatterie.de* in the address line of your browser.

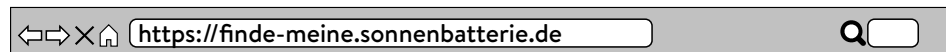

The following window appears:

Figure 54: *finde-meine.sonnenbatterie.de*

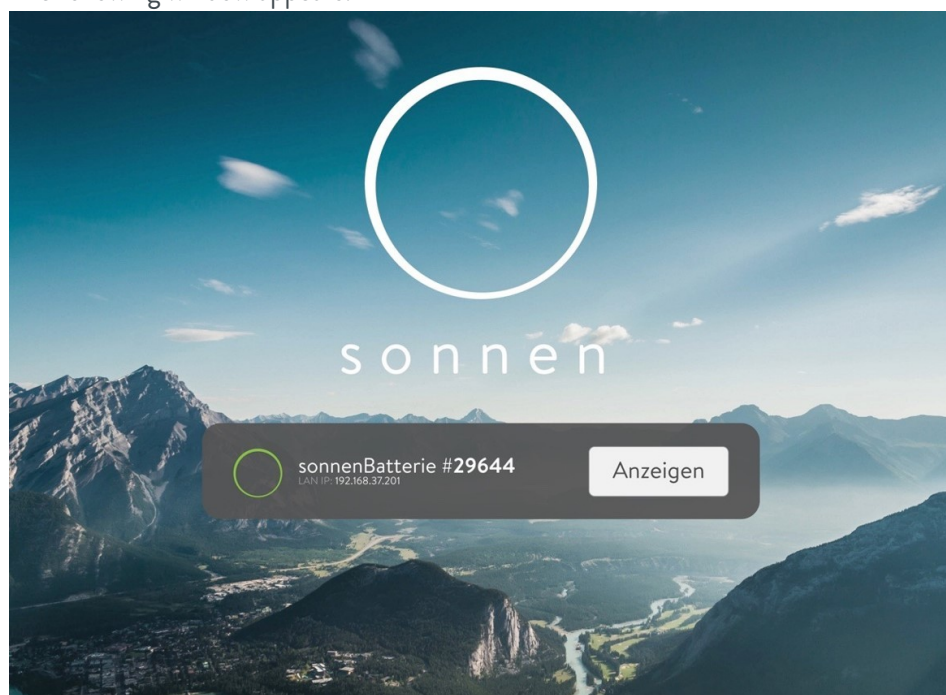

► Click the button *Anzeigen*.

The login page appears.

If the page *finde.meine.sonnenbatterie.de* does not appear or the storage system is not displayed:

► Follow the instructions in section 8 (S. 59).

### 7.3.2 Running the commissioning wizard

- ▶ Select your preferred language from the *language selection list* (1).
- ▶ Select the User *Installer* from the *user selection list* (2).
- ▶ Enter **Sonnen@Installer2016** in the password entry box (3).
- ▶ Click the button (4) to confirm your entries.

Figure 55:  
login page

- |   |                         |
|---|-------------------------|
| 1 | Language selection list |
| 2 | User selection list     |
| 3 | Password entry box      |
| 4 | Confirm button          |

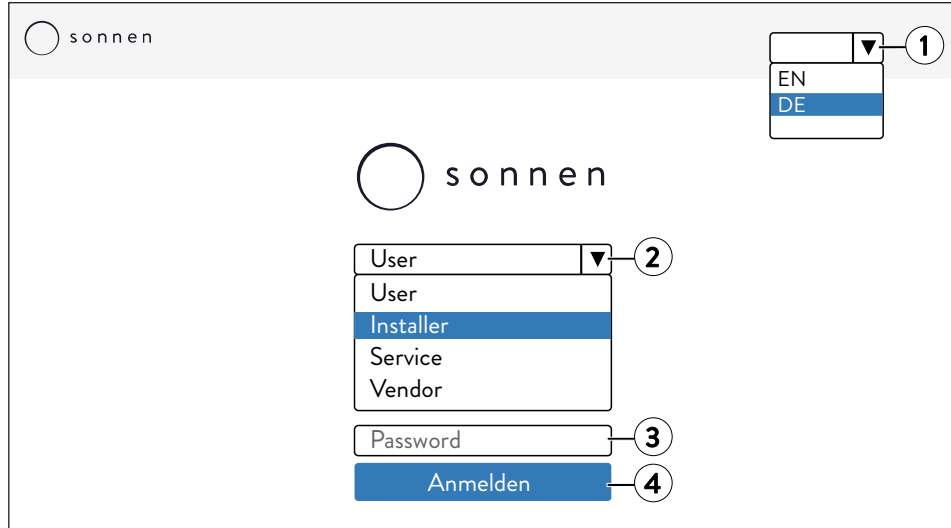

After that the commissioning wizard will start.

- ▶ Run the commissioning wizard until it is fully completed.

# 8 Troubleshooting

disturbance	reason	correction
-------------	--------	------------

No internet connection (the storage system is not displayed at the Internet portal <https://meine.sonnenbatterie.de>)

- No connection between the storage system and the server.

► Make sure that the Ethernet line between the storage system and the Router of the home network is correctly connected.

► Make sure that the Router of the home network allows connections on the following ports:

TCP-Port	Service
22	SecureShell (ssh)
37	Time Server (ntp)
80	Online-Check (http)
222	VPN (Serververbindung ssl)
232	VPN (backup)
443	App-Steuerung (https)
UDP-Port	Service
1196	(Serververbindung, ssl)

## 9 Decommissioning

### Notice

#### Damage to battery modules due to deep-discharge!

Without a connection to the public electrical mains, the battery modules may be damaged due to being deep-discharged.

- ▶ Do not disconnect the storage system from the public electrical mains for an extended period of time.

Figure 56:  
Fuse switch F1 and switch S1 on top of  
the storage system

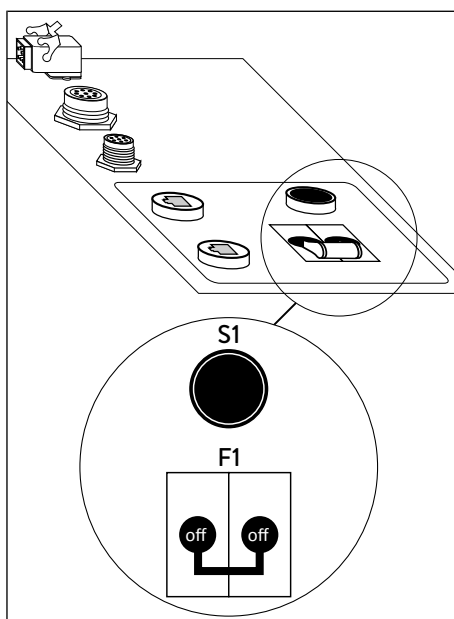

- ▶ Remove the cover at the top side of the storage system (see chapter 7.2.1 – p. 55).

- ▶ Switch off F1.

## 10 Uninstallation and disposal

### 10.1 Uninstallation

#### DANGER

##### Improper uninstallation of the storage system

Danger to life due to electrocution!

- ▶ The storage system must only be uninstalled by authorised electricians.

### 10.2 Disposal

#### CAUTION

##### Improper transport of battery modules

Fire outbreak at battery modules or emission of toxic substances!

- ▶ Transport the battery modules in their original packaging only. If you no longer have the original packaging, new packaging can be requested from sonnen GmbH.
- ▶ Never transport damaged battery modules.

Figure 57:  
WEEE symbol

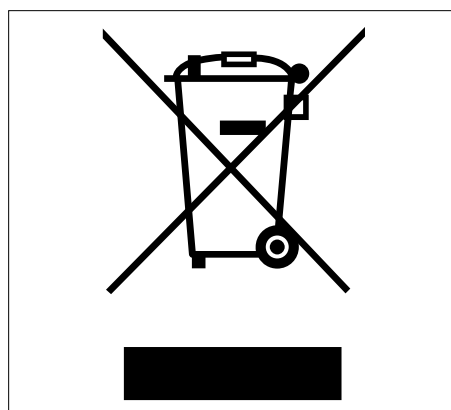

The storage system and the batteries it contains must **not** be disposed of as domestic waste.

- ▶ Dispose of the storage system and the batteries it contains in an environmentally friendly way through suitable collection systems.
- ▶ Contact sonnen GmbH to dispose of old batteries. In accordance with the German Battery Act (BattG 2009), sonnen GmbH will accept old batteries free of charge. Please note that the cost of transporting old batteries is not covered.

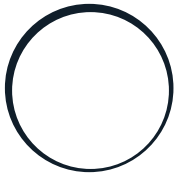

sonnen

**sonnen GmbH**

Am Riedbach 1

D-87499 Wildpoldsried

t +49 (0) 8304 / 92933 - 444

o [info@sonnenbatterie.de](mailto:info@sonnenbatterie.de)

# 11 Commissioning report

The completed commissioning report must be sent to the following email address within 5 working days of successful commissioning:  
service@sonnenbatterie.de

## Commissioning details

Storage system serial number:	Date of commissioning:		
-------------------------------	------------------------	--	--

## Operator details

Surname, first name	Street	Post code, town
Telephone	Email address	

## Storage system location (only required if location is different from the address above)

Street	Post code, town	
--------	-----------------	--

## Specialist company details

Company	Street	Post code, town
Telephone	Email address	

## Details on electrician carrying out the work

Name	Company	Certification number
------	---------	----------------------

## Details on network topology (mark off the applicable network)

TT |  TN-S |  TN-C-S |  TN-C |  TN-C (classic earthing)

## Details on PV system

Feed-in: <input type="checkbox"/> one-phase   <input type="checkbox"/> three-phase	Feed-in via phase: <input type="checkbox"/> L1   <input type="checkbox"/> L2   <input type="checkbox"/> L3
Nominal power of PV system	

## Special notes/points to be addressed

--

## Electrician's declaration

I confirm that my details are correct. The storage system was installed and commissioned by me in the proper manner. I followed the installation instructions in doing so.

Place, date	Electrician's signature	
-------------	-------------------------	--

## Operator's declaration

I confirm that my details are correct.

Place, date	Operator's signature	
-------------	----------------------	--