



Installation instructions | for licensed electricians

sonnenBackup-Box

for sonnenBatterie eco 8.0, hybrid 8.1 and pro 2.0

EN

IMPORTANT

- ▶ Read this documentation carefully before installation / operation.
- ▶ Retain this document for reference purposes.

Publisher

sonnen GmbH

Am Riedbach 1

D-87499 Wildpoldsried

Service number

+49 8304 92933 444

Email

info@sonnen.de

Document

Document number

492

Part number

22320

Version

X02

Valid for

AU, NZ

Publication date

16/01/2019

9007199347281931

Table of contents

1	Information about this document	5
1.1	Target group of this document	5
1.2	Designations in this document	5
1.3	Explanation of symbols	5
2	Safety	6
2.1	Intended use	6
2.2	Requirements for the electrician	6
2.3	Operating the product	6
2.4	Product modifications or changes to the product environment	7
2.5	Voltage inside the Backup-Box	7
3	Product description	8
3.1	Technical data	8
3.2	System components	9
3.2.1	System components of the Backup-Box	9
3.2.2	Inverters of the Backup-Box	10
3.2.3	Connections on the Backup-Box	11
3.3	Type plate	12
3.4	Symbols on the outside of the Backup-Box	12
3.5	Storage and transport	13
4	Mounting	14
4.1	Scope of delivery	14
4.2	Additional parts required	14
4.3	Selecting the installation location	15
4.3.1	Requirements for the installation location	15
4.3.2	Observe minimum and maximum distances	15
4.4	Mounting the Backup-Box	15
4.4.1	Requirements for mounting material	15
4.4.2	Drilling the holes	15
4.4.3	Fastening the Backup-Box	16
5	Electrical installation	17
5.1	Emergency operation design	18
5.2	Positioning components in the electrical distributor	19
5.3	Wiring components in the electrical distributor	19
5.4	Attaching safety label to the distributor	21
5.5	Connection to the Backup-Box	22
5.5.1	Connecting earthing cables	22
5.5.2	Routing the battery cables	23
5.5.3	Connecting the mains cables	24
5.5.4	Routing the control signal cable	25
5.5.5	Using the signalling contact	25
5.6	Connection to the storage system	26
5.6.1	Routing cables into the storage system	26
5.6.2	Connecting the earthing cable	27

5.6.3	Connecting the battery cables.....	28
5.6.4	Connecting the control signal cable	29
6	Commissioning	32
6.1	Commissioning checklist	32
6.2	Switching on the Backup-Box and the storage system	32
6.3	Setting up the Backup-Box.....	32
6.4	Setting the backup buffer	32
6.5	Testing backup operation	33
6.6	Filling in the commissioning report.....	33
7	Decommissioning	34
7.1	Switching off the Backup-Box.....	34
7.2	Disconnecting the Backup-Box from the power supply	34
8	Uninstallation and disposal	35
8.1	Uninstallation.....	35
8.2	Disposal.....	35
9	Troubleshooting	36
10	Commissioning report sonnenBackup-Box	37

1 Information about this document

This document describes the installation of the sonnenBackup-Box in connection with the storage system sonnenBatterie eco 8.0, hybrid 8.1 or pro 2.0.

- ▶ Read this document in its entirety.
- ▶ Keep this document in the vicinity of the sonnenBatterie.

1.1 Target group of this document

This document is intended for licensed electricians. The actions described here must only be performed by licensed electricians.

1.2 Designations in this document

The following designations are used in this document:

Complete designation	Designation in this document
sonnenBatterie eco 8.0 (incl. pro 2.0)	Storage system
sonnenBatterie hybrid 8.1	
sonnenBackup-Box	Backup-Box

1.3 Explanation of symbols



DANGER

Extremely dangerous situation leading to certain death or serious injury if the safety information is not observed.



WARNING

Dangerous situation leading to potential death or serious injury if the safety information is not observed.



CAUTION

Dangerous situation leading to potential injury if the safety information is not observed.

NOTICE

Indicates actions that may cause material damage.



Important information not associated with any risks to people or property.

Symbol	Meaning
▶	Work step
1. 2. 3. ...	Work steps in a defined order
✓	Condition
•	List

Table 1: Additional symbols

2 Safety

2.1 Intended use

The sonnenBackup-Box is an emergency power unit designed to supplement the sonnenBatterie eco 8.0, hybrid 8.1 or pro 2.0. The Backup-Box - in conjunction with the appropriate storage system of the sonnen GmbH - serves to supply power in the event of a power failure. Any other use is considered improper use.

Improper use poses a risk of death or injury to the user or third parties as well as damage to the product and other items of value. The following points must therefore be observed in order to comply with the intended use of the product:

- Only operate the Backup-Box together with the right storage system.
- The Backup-Box must be installed by a licensed electrician.
- The Backup-Box must only be connected to the storage system as described here.
- Isolated operation is **not** possible with the Backup-Box. A generator (e. g. a PV system) must never be connected after the output of the Backup-Box.
- Intended use includes observing this document as well as all accompanying product documentation of the appropriate storage system.
- The Backup-Box must only be used at suitable installation location.
- The transport and storage conditions must be observed.

Especially the following uses are not permissible:

- Operation in flammable environments or areas at risk of explosion.
- Operation in locations at risk of flooding.
- Operation outdoors.



Failure to comply with the conditions of the warranty and the information specified in this document invalidates any warranty claims.

2.2 Requirements for the electrician

Improper installation can result in personal injury and/or damage to components. For this reason, the Backup-Box must only be installed and commissioned by licensed electricians. Licensed electricians must meet the following criteria:

- The electrician must be a person with a technical knowledge or sufficient experience to enable him/her to avoid dangers which electricity may create.
- The electrician must have successfully completed the sonnen Australia installer training and have valid installer accreditation at the time of installation.

2.3 Operating the product

Incorrect operation can lead to injury to yourself or others and cause damage to property.

- The Backup-Box must only be operated as described in the product documentation.
- This device can be used by children from the age of eight (8) years old and individuals with impaired physical, sensory or mental capabilities or individuals with limited knowledge and/or experience of working with the device, as long as they are supervised or

have been trained to safely use the device and understand the resulting risks of doing so. Children must not play with the device. Cleaning and user maintenance must not be carried out by children without supervision.

2.4 Product modifications or changes to the product environment

- The Backup-Box must only be used in its original state without any user modifications and only when in perfect working order.
- Safety devices must never be overridden, blocked or tampered with.
- The interfaces of the Backup-Box and the storage system must be wired in accordance with the product documentation.
- All repairs on the Backup-Box must be performed by authorised service technicians only.

2.5 Voltage inside the Backup-Box



The Backup-Box contains live electrical parts, which poses a risk of electrical shock. The Backup-Box and storage system inverter also contain capacitors which carry voltage even after the storage system is switched off.

Therefore:

- ▶ Disconnect the Backup-Box and the storage system from the power (see Switching off the Backup-Box [P. 34] and the product documentation of the storage system).

Only then can the Backup-Box be opened.

3 Product description

3.1 Technical data

sonnenBackup-Box	
System data	
Maximum power (2 sec.)	4,100 VA
Overload (30 min.)	max. 2,800 VA
Nominal power	1,800 VA
Nominal frequency	50 Hz
Output voltage	230 VAC +/- 10 %
Mains connection	three-phase, L1 / L2 / L3 / N / PE
Mains connection fuse	Miniature circuit breaker Type C 32 A
Operating concept	Single-phase emergency power supply. The switch to emergency operation takes place automatically through the storage system.
Switchover time	approx. 3 seconds
Mains topology	TN / TN-S / TN-C-S
Threshold power	approx. 5 W
Dimensions / Weight	
Dimension (H/W/D) in cm	70/67/23
Weight in kg	46
Safety / Protective devices	
Protection class	I / PE conductor
Degree of Protection	IP30
Protective functions	Overvoltage protection, Overcurrent protection, Overtemperature protection
Residual current device (RCD)	External RCD required
Separation principle Batt. -> AC	galvanic isolation
Ambient conditions	
Environment	Indoor (conditional)
Ambient temperature range	-5 °C ... 45 °C
Max. rel. humidity	90 %, non-condensing
Permissible installation altitude	2,000 m above sea level
Additional ambient conditions	The ambient conditions prescribed for the storage system apply.

3.2 System components

3.2.1 System components of the Backup-Box

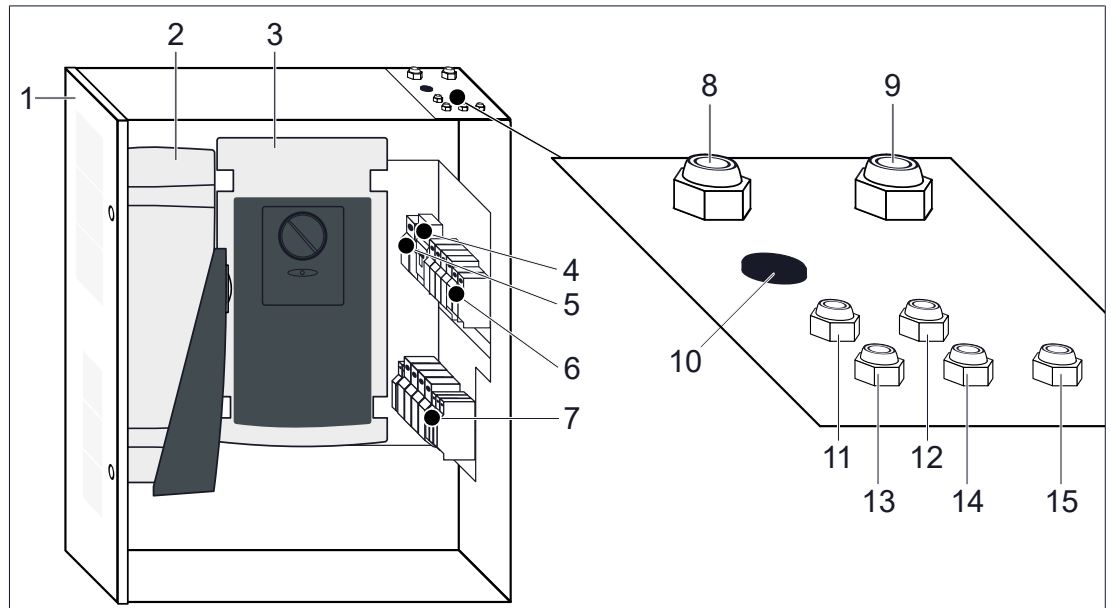

Illustration 1: System components of the Backup-Box

- | | |
|----------------------------------|--------------------------------|
| 1 Backup-Box | 5 X3.B terminal strip position |
| 2 Slave inverter | 6 X1.B terminal strip position |
| 3 Master inverter | 7 X2.B terminal strip position |
| 4 F1.B Miniature Circuit Breaker | |

Cable glands

- | | |
|----------------------------------|---------------------------------------------|
| 8 Mains IN | 12 Minus (negative) battery cable |
| 9 Mains OUT | 13 Control signal cable |
| 10 Cable for signalling contact | 14 Earthing cable to storage system |
| 11 Plus (positive) battery cable | 15 Earthing cable to main earthing terminal |

3.2.2 Inverters of the Backup-Box

NOTICE

Incorrect switch position on the inverters

Damage to the inverters of the Backup-Box!

The correct switch position was marked by a label.

- ▶ Do not change the switch position of the rotary switches on the two inverters of the Backup-Box.

The two inverters within the Backup-Box each have a rotary switch and an LED light.

Rotary switch

It is essential for the function of the Backup-Box that the rotary switches on both inverters are set correctly. The rotary switches have been factory set in the correct position and this position has been marked by a sticker.

- ▶ Do not change the switch position on the inverters.
 - Master inverter: STANDBY area.
 - Slave inverter: OFF.

LED light

The LED light indicates the current state of the inverter:

LED colour	Status	Meaning
-	Off	Power supply switched off
green	Permanently illuminated	Consumer device switched on
	Blinking slowly	Standby operation, no consumer device was recognized
red	Blinking slowly	System error; please contact the sonnen Service
	Blinking quickly	Overcurrent
	Permanently illuminated	Overheating
red-green	Blinking slowly	Battery undervoltage or low charge state
	Blinking quickly	Battery overvoltage

3.2.3 Connections on the Backup-Box

The positions of the terminal strips or terminals inside the Backup-Box can be found in section System components of the Backup-Box [P. 9].

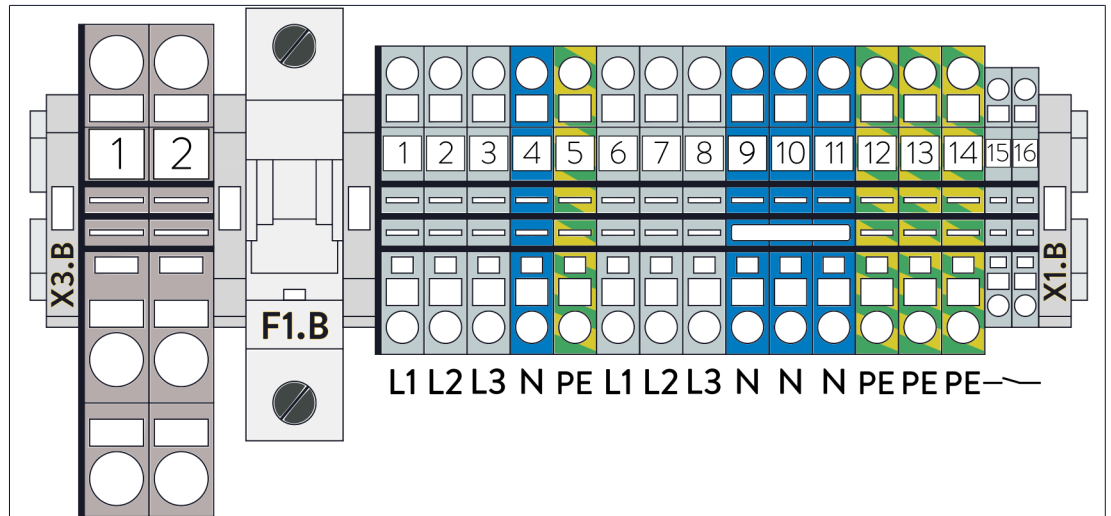

Illustration 2: Terminal strips X1.B and X3.B as well as Miniature circuit breaker F1.B

X1.B terminal strip overview

Terminal	Function
1-3	AC line IN phase 1-3
4	AC line IN neutral conductor
5	AC line IN earthing conductor
6-8	AC line OUT phase 1-3
9	AC line OUT neutral conductor
10	AC line OUT neutral conductor – free
11	AC line OUT neutral conductor – free
12	AC line OUT earthing conductor
13	Earthing conductor to storage system
14	Earthing conductor to main earthing terminal
15	Potential-free signalling contact – closed in backup operation
16	Potential-free signalling contact – closed in backup operation

X3.B terminal strip overview

Terminal block	Terminal	Function
X3.B	1	Plus (positive) battery voltage
X3.B	2	Minus (negative) battery voltage

Control signal connection overview

Terminal strip:terminal	Wire colour	Function
X2.B:9	White	GND (earth)
F3.B	Brown	Supply voltage 24 V DC
K5.B:A1	Yellow	Digital output (DO) for emergency shutdown
K6.B:14	Green	Digital input (DI) for grid detection (backup supply active)

3.3 Type plate

The type plate is located on the outer surface of the Backup-Box. The type plate can be used to uniquely identify the Backup-Box. The information on the type plate is required for the safe use of the system and for service matters.

The following information is specified on the type plate:

- Item designation
- Item number
- Technical data

3.4 Symbols on the outside of the Backup-Box

Symbol	Meaning
	Warning: flammable materials.
	Warning: hazards due to batteries.
	Warning: electrical voltage.
	Warning: electrical voltage. Wait five minutes after switching off (capacitor de-energising time).
	Warning: The information in the manuals regarding the rotary switch settings must be observed.
	Warning: product is heavy.
	CE mark. The product meets the requirements of the applicable EU Directives.
	WEEE mark. The product must not be disposed of in household waste, dispose of it through environmentally friendly collection centres.

Symbol	Meaning
	<p>Observe the documentation. The documentation contains safety information.</p>

3.5 Storage and transport

Storage and transport conditions are defined in the product documentation of the storage system.

- ▶ Observe the same storage and transport conditions for the Backup-Box.

4 Mounting

4.1 Scope of delivery

- ▶ Check the following scope of delivery to ensure it is complete.

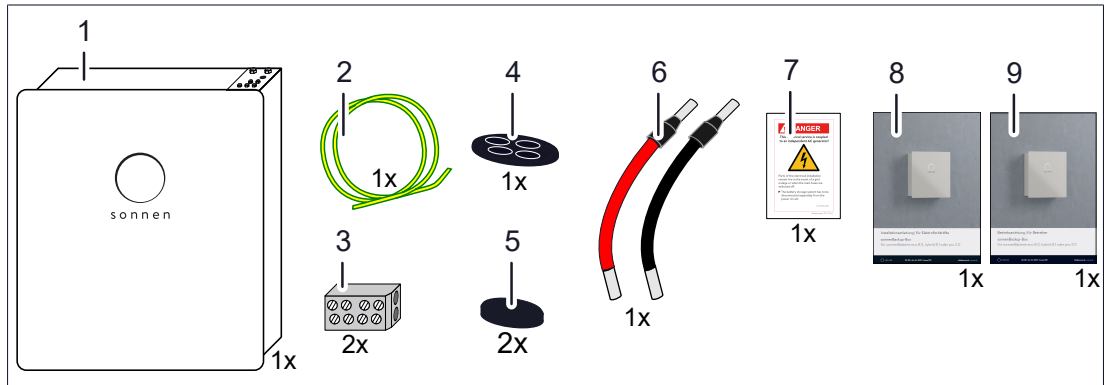

- 1 Backup-Box incl. internally pre-assembled lines (Battery lines, Control signal line)
- 2 Earthing line for connection to the storage system
- 3 Branch terminal
- 4 Cable entry plate, round
- 5 Blanking plug with membrane grommet
- 6 Battery line, red and black
- 7 Safety label
- 8 Installation instructions
- 9 Operating instructions

4.2 Additional parts required

- ▶ The following components are not included in delivery and must be selected and ordered by the qualified electrician accordingly:

2 x mains connection cable (for Connecting the mains cables [P. 24])

- Cable cross-section as per country-specific specification (at least 5G6mm²).

1 x earthing cable (for Connecting earthing cables [P. 22])

- Cable cross-section: 10 mm².

Optional: Cable gland with multi-seal insert (see Routing cables into the storage system [P. 26]).

4.3 Selecting the installation location

4.3.1 Requirements for the installation location

- ▶ Observe the required ambient conditions (see Technical data [P. 8]).

4.3.2 Observe minimum and maximum distances

- The Backup-Box should be mounted to the right or left of the storage system.
- ▶ Install the Backup-Box at the same level as the top edge of the storage system, if possible.

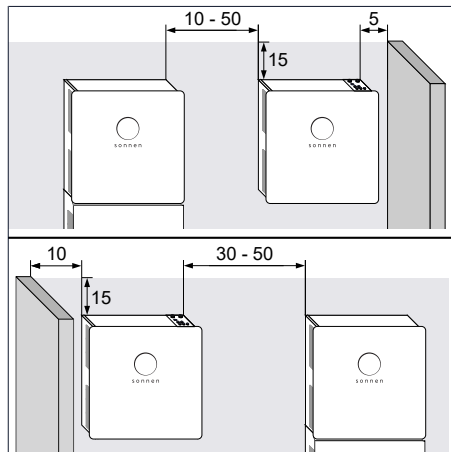

Illustration 3: Distances to the Backup-Box
(Figure not to scale - all specifications in centimetres)

- ▶ Observe the specified **maximum** distances between the Backup-Box and the storage system, so that the length of the pre-assembled and supplied cables is sufficient.
- ▶ Observe the specified **minimum** distances to the storage system and neighbouring objects, so that there is sufficient heat dissipation, the door can be opened easily and there is sufficient space for installation and maintenance work.

4.4 Mounting the Backup-Box

4.4.1 Requirements for mounting material

- ▶ Use only screws with the following properties:

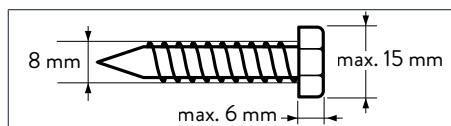

Illustration 4: Parameters of the screw used

- Screw head diameter: max. 15 mm
- Screw diameter: 8 mm
- Height of screw head: max. 6 mm

- The screw lengths and the wall plugs used must be suitable for the nature of the wall.

4.4.2 Drilling the holes



A drilling template is part of the packaging of the Backup-Box. Therewith it is easier to mark the position of the holes on the wall. Please use the holes marked as 'base cabinet' for the Backup-Box.

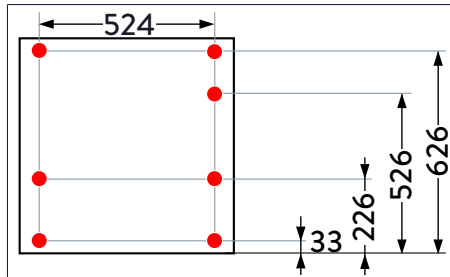

Illustration 5: Drill template for Backup-Box
(Figure not to scale - all specifications in millimetres)

- ▶ Drill the holes shown in red in the illustration on the left.

4.4.3 Fastening the Backup-Box

1. Apply the screws

There are keyhole attachments on the rear of the Backup-Box. The Backup-Box is mounted using these attachments.

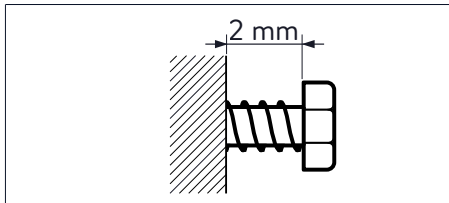

Illustration 6: Distance between screw head and wall

The screw should not be completely screwed in. The screw head should protrude from the wall by approx. 2 mm.

- ▶ Apply suitable screws and anchors (see Requirements for mounting material [P. 15]) to the previously drilled holes.

2. Attach the Backup-Box

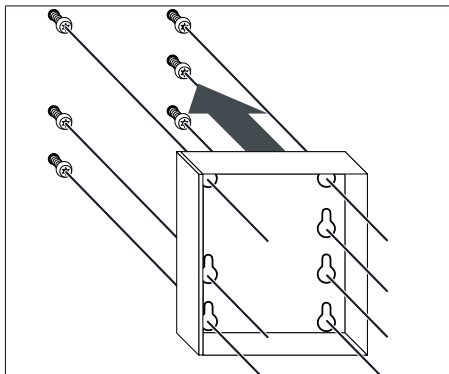

Illustration 7: Hanging up the Backup-Box

- ▶ Attach the Backup-Box to the previously mounted screws.

3. Tighten the screws

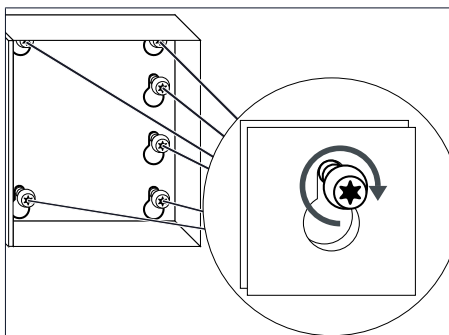

Illustration 8: Tightening the screws

- ▶ Tighten all visible screws.

5 Electrical installation

DANGER

Electrical work on the storage system and electrical distributor

Danger to life due to electrocution!

- ▶ Switch off the storage system to electrically isolate it.
- ▶ Disconnect the relevant electrical circuits.
- ▶ Secure against anyone switching on the device again.
- ▶ Wait five minutes so the capacitors can discharge.
- ▶ Check that the device is disconnected from the power supply.
- ▶ Only licensed electricians are permitted to carry out electrical work.

DANGER

Touch voltage in the event of a fault during backup operation

Danger to life due to electrocution!

- ▶ A residual current device (RCD) must be installed downstream of the output of the Backup-Box.

NOTICE

Observe maximum line lengths

- ▶ None of the lines connected to the Backup-Box and the storage system (mains line, ethernet line, other data lines) are allowed to exceed a maximum length of 30 m.

5.1 Emergency operation design

Before installation, the installer must explain or clarify with the operator the following points.

- Emergency operation does not offer the same output as grid operation.
- Three-phase current is not available during emergency operation (as only one phase is supplied with power).
- **Which consumers should be supplied with power in emergency operation?** The current paths in the building network can be installed in such a way that phase L1 of the Backup-Box (**emergency phase**) is laid on the phase that supplies power to the relevant consumers. The electrical consumers which are crucial for the operator in emergency operation are relevant here. Different consumers which may be important during a grid outage are specified in the sample calculation presented below.
- **How much capacity of the storage system should be reserved as an emergency buffer?** The following example can be used to determine this. This example is based on a grid outage lasting one hour (the individual power consumption values are estimated values).

Electrical consumer	Power consumption [W]	Active during grid outage [h]	Electrical work [kWh]
Refrigerator	600	0.25	0.15
Freezer	600	0.25	0.15
Heating	700	0.25	0.175
Door/garage door opener	50	0.1	0.005
Aquarium pump	20	1	0.02
Lighting	500	1	0.5
Router, telephone	10	1	0.01
Flat-screen television/radio	100	1	0.1
Alarm system, grid-connected smoke detector	50	1	0.05
		Total	1.16

In this example, the total power requirement for a grid outage lasting one hour is approx. 1.2 kWh, in order to maintain the function of all of the listed consumers.

- ▶ Use this calculation to determine with the operator which emergency buffer should be set, taking the total capacity of the storage system and other requirements (e.g. from sonnenFlat tariff) into account (see Setting the backup buffer [P. 32]).

5.2 Positioning components in the electrical distributor

The following components must be installed in the electrical distributor for the Backup-Box:

- **Circuit breaker (miniature) | type C | 32 A**

A miniature circuit breaker with type C tripping characteristics and a nominal current of 32 A must be installed *upstream of the input* for the Backup-Box.

- **Residual current device (RCD)**

A residual current device must be installed *at the output* of the Backup-Box. This RCD protects against electrocution during backup operation. An RCD must be used which complies with the respective country-specific regulations and the local network conditions.

- **In network with TT earthing: Additional residual current device (RCD) | 300 mA**

In networks with TT earthing, an additional residual current device must be installed *upstream of the input* for the Backup-Box. An RCD with a nominal differential current of 300 mA is sufficient for this. RCDs with a nominal differential current of 100 mA or 30 mA can also be used. A selective residual current device must be used.

5.3 Wiring components in the electrical distributor

- ▶ Wire the components previously installed in the electrical distributor as shown in the following figure.

Note:

The figure on the following page shows a connection diagram with an overview of the electrical connections of a storage system with the Backup-Box. Two areas **A** and **B** are labelled in the figure.

- The figure shows the installation of a **sonnenBatterie eco 8.0** as an example, which has been installed in accordance with the specifications in the product documentation (area **A**) and to which a Backup-Box has now been added (area **B**).
- In the case of a **sonnenBatterie hybrid 8.1, pro 2.0** or a **sonnenFlat**, the installation of the Backup-Box (area **B**) is identical, but the installation of the storage system itself in area **A** differs.
- ▶ ***The information on the differing electrical installations can be found in the documentation for the product in question.***

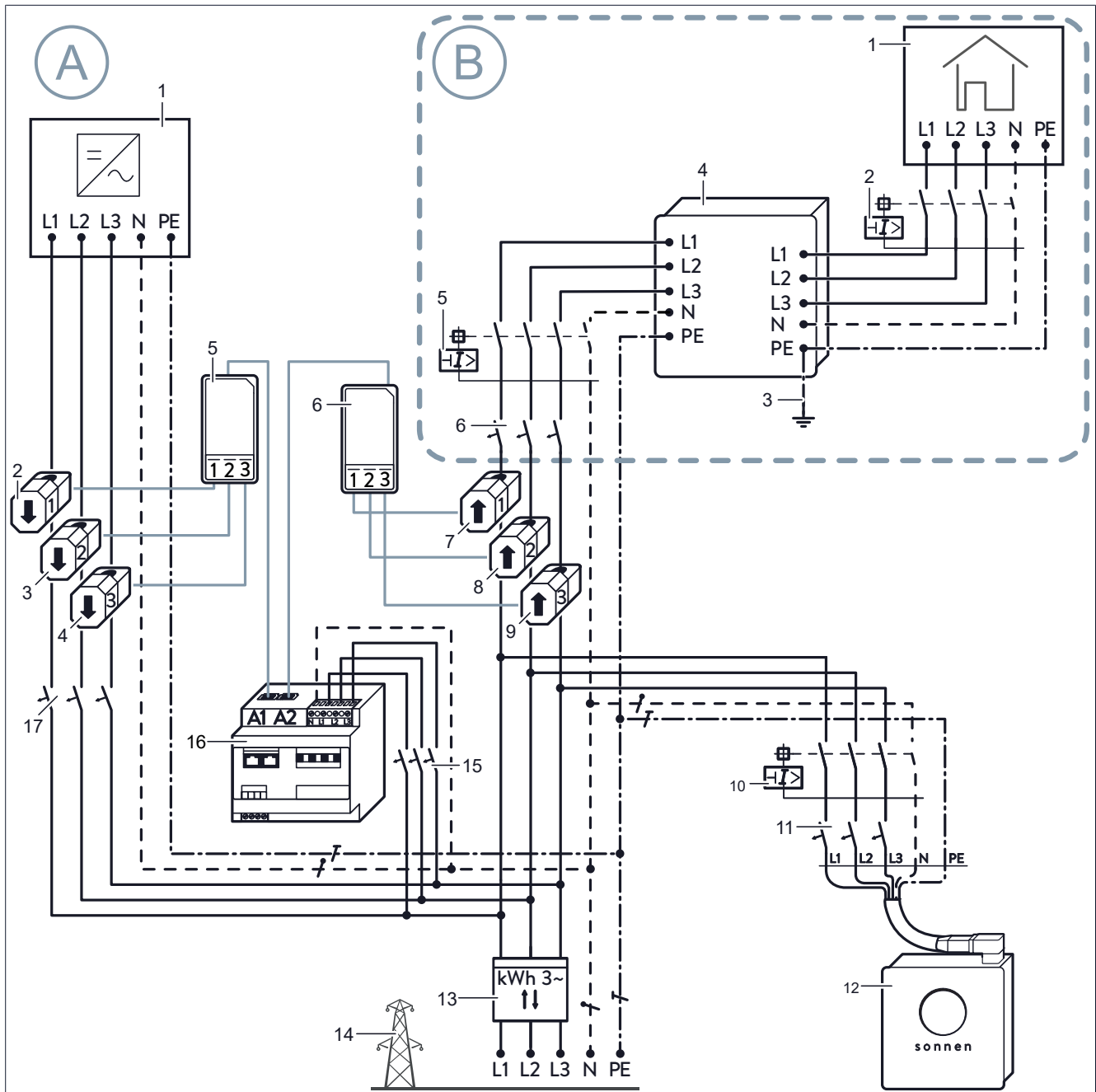

Section A - Existing installation of the storage system

- | | | |
|------------------------------------------|--------------------------------------|----------------------------|
| 1 PV inverter | 7 Current transformer consumption L1 | 13 Bidirectional counter |
| 2 Current transformer generation L1 | 8 Current transformer consumption L2 | 14 Public electrical mains |
| 3 Current transformer generation L2 | 9 Current transformer consumption L3 | 15 Power meter MCB |
| 4 Current transformer generation L3 | 10 RCD ¹ | 16 Power meter |
| 5 Transformer interface generation (A1) | 11 Storage system MCB ² | 17 PV inverter MCB |
| 6 Transformer interface consumption (A2) | 12 Storage system | |

Section B - Altered installation by Backup-Box

- | | | |
|-------------------------|--------------------|---------------------------------------------|
| 1 Consumers in building | 3 Earth connection | 5 RCD (in TT networks) |
| 2 RCD | 4 Backup-Box | 6 Miniature circuit breaker Type C 32 A |

¹ According to the requirement in the installation instructions of the storage system.

² Miniature Circuit Breaker.

5.4 Attaching safety label to the distributor

⚠ DANGER

Electrical installation remains live in event of grid outage

Danger to life due to electrocution!

To warn electricians:

- ▶ Attach the safety label shown below (included in scope of delivery) to the relevant electrical distributor.

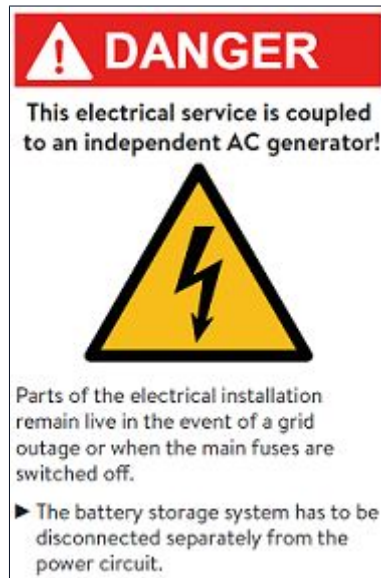

Illustration 9: Label for attachment to the electrical distributor

5.5 Connection to the Backup-Box

5.5.1 Connecting earthing cables

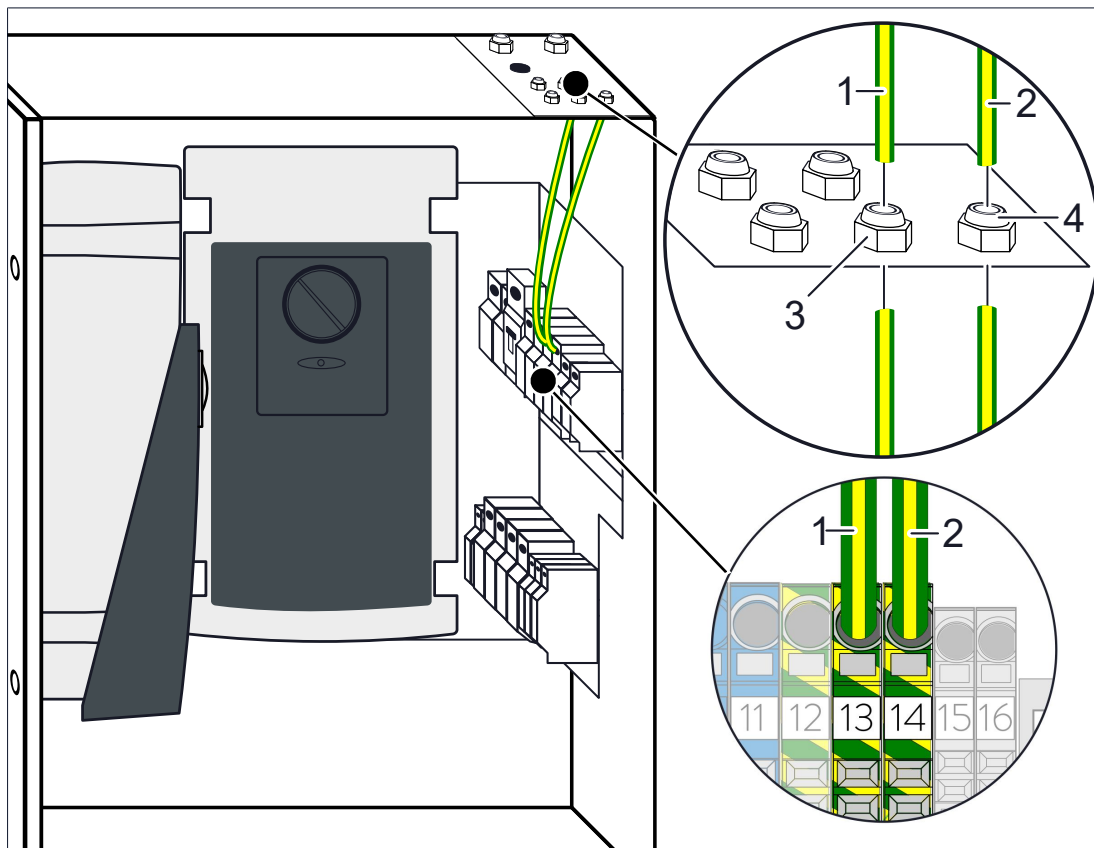

Illustration 10: Connecting earthing cables

Connecting the housing

An earth connection must be established between the housings of the Backup-Box and of the storage system. This ensures that both housing have the same potential.

- ▶ Direct the supplied earthing cable through the designated cable gland (3) into the Backup-Box.
- ▶ Connect the earthing cable (1) to terminal **13** of terminal strip **X1.B**.
- ▶ Connect the earthing cable in the storage system as shown in section Connecting the earthing cable [P. 27].

Earthing the Backup-Box

A PE conductor with a cross-section of 10 mm² (CU cross-section) must be installed between the Backup-Box and the main earthing terminal. This earth connection is required in application rule VDE-AR-E 2510-2.

Direct the corresponding earthing cable through the designated cable gland (4) into the Backup-Box.

- ▶ Connect the earthing cable (2) to terminal **14** of terminal strip **X1.B**.
- ▶ Connect the earthing cable to the main earthing terminal in the electrical distributor.

5.5.2 Routing the battery cables

- The battery cables are already connected inside the Backup-Box.

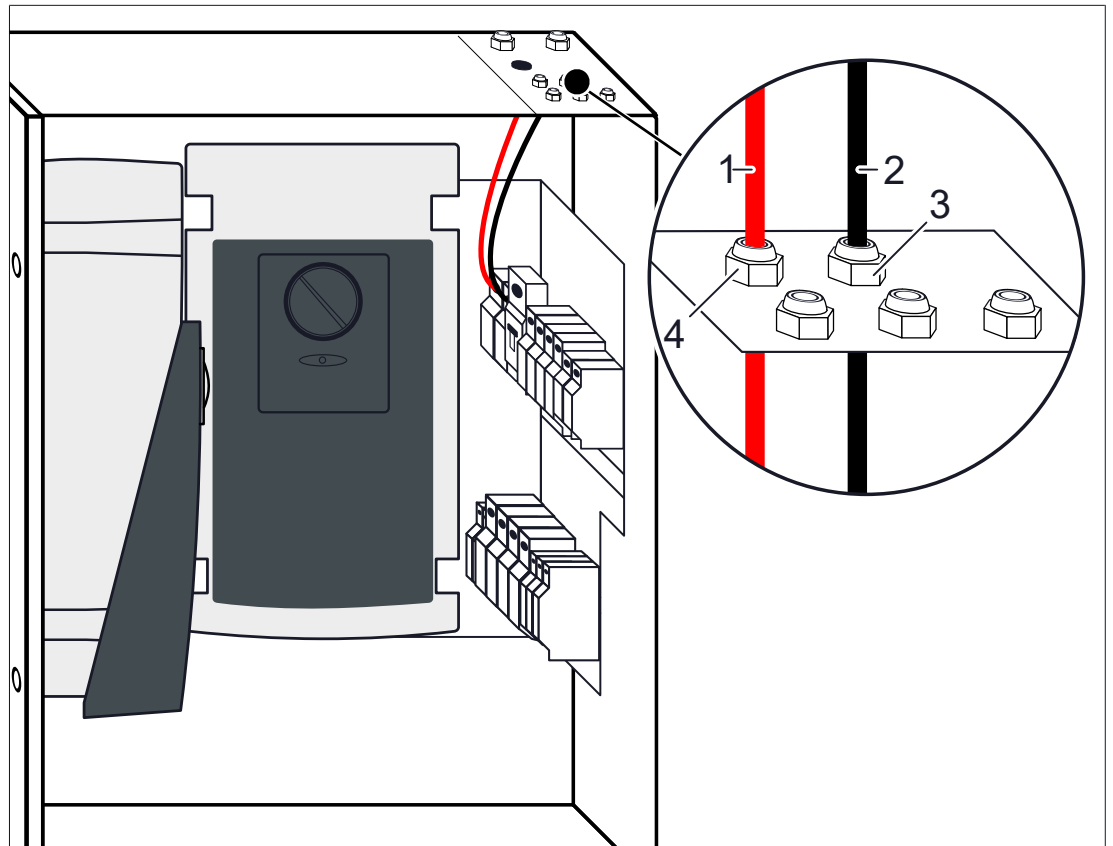

Illustration 11: Connecting the battery cables

- ▶ Direct the two battery cables (1 + 2) outwards through the designated cable glands (3 + 4) on the top of the Backup-Box.
- ▶ Connect the battery cables in the storage system as shown in section Connecting the battery cables [P. 28].

5.5.3 Connecting the mains cables

DANGER

Work on the electrical distributor

Danger to life due to electrocution!

- ▶ Disconnect the relevant electrical circuits.
- ▶ Secure against anyone switching on the device again.
- ▶ Check that the device is disconnected from the power supply.
- ▶ Only licensed electricians are permitted to carry out electrical work.

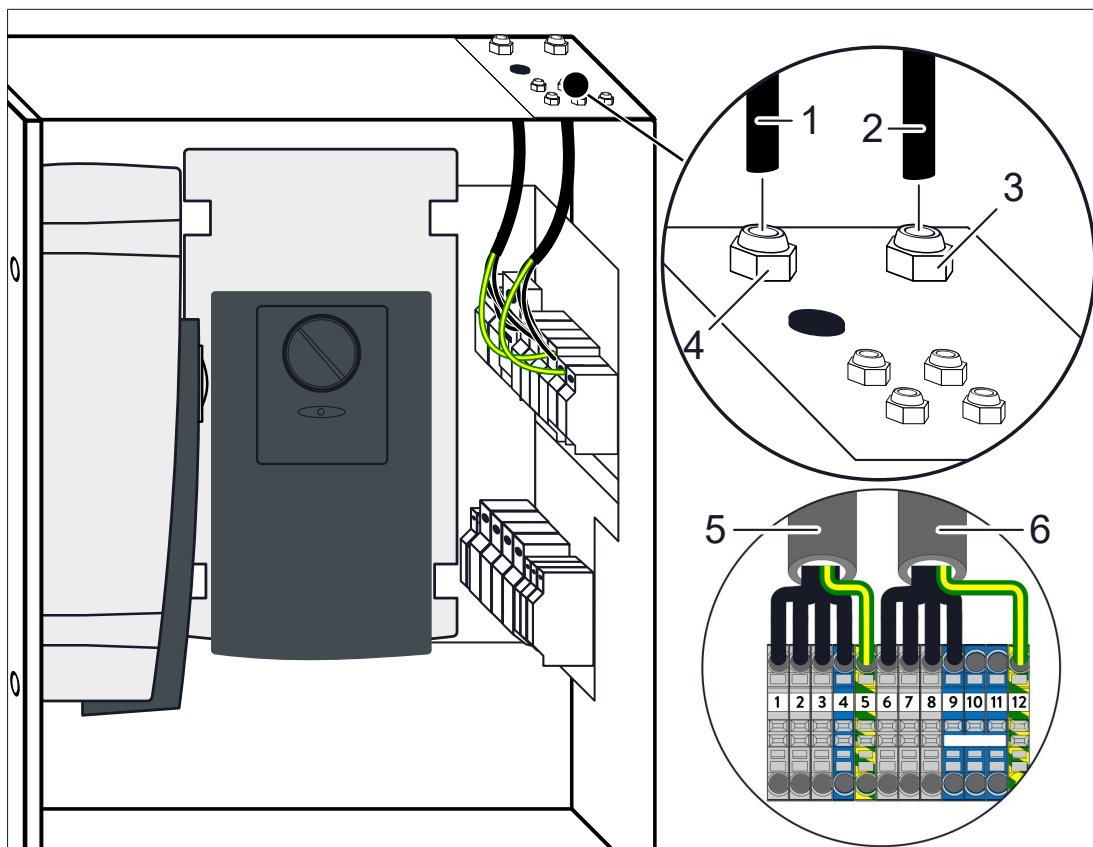

Illustration 12: Connecting the mains cable

- 1, 5 AC line mains supply IN
- 2, 6 AC line consumer OUT
- 3 Cable gland OUT
- 4 Cable gland IN

- ▶ Direct the supply IN line stipulated by requirements (1) through the designated cable gland (4) on the top of the Backup-Box. The OUT line (2) is directed through the cable gland next to this (3).
- ▶ Connect the individual wires of the supply IN line (1, 5) to terminals **1-5** of terminal strip **X1.B**.
- ▶ Connect the individual wires of the OUT line (2, 6) to terminals **6-9** and terminals **12** of terminal strip **X1.B**.

5.5.4 Routing the control signal cable

- Signals are transmitted between the Backup-Box and storage system via the control signal cable.
- The control signal cable is already connected inside the Backup-Box.

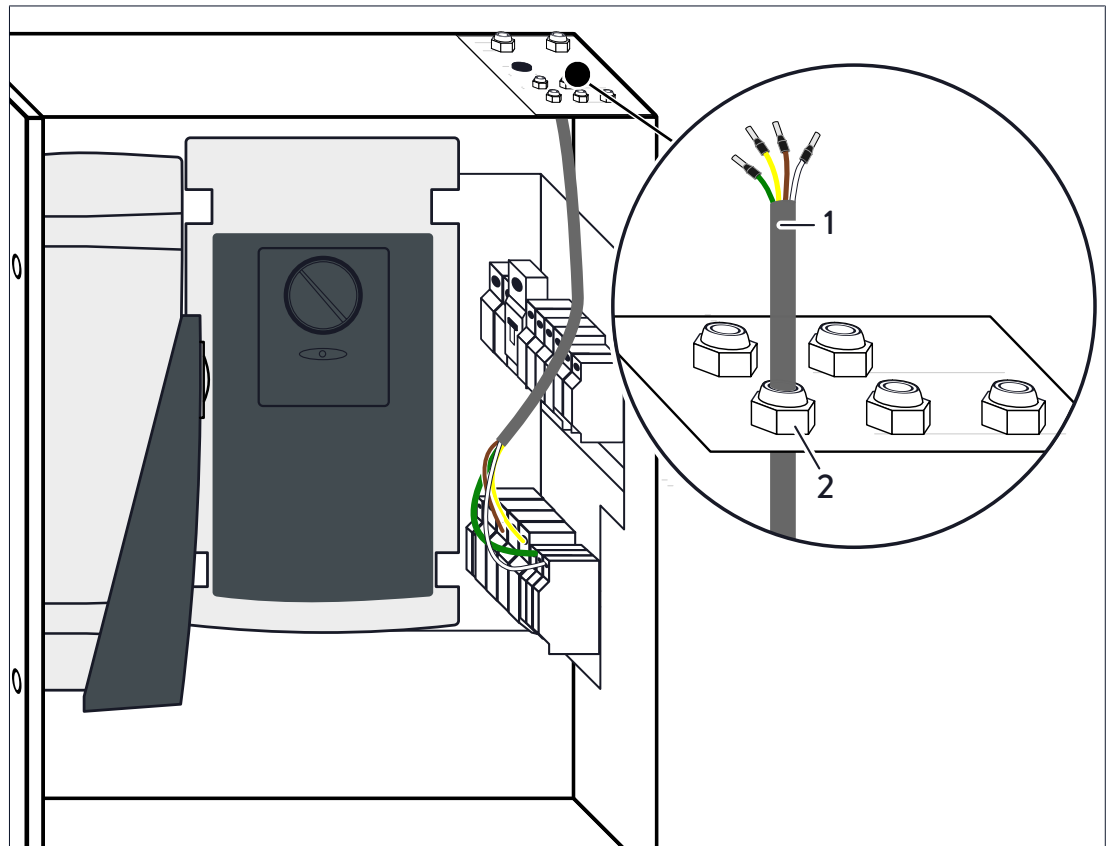

Illustration 13: Routing the connected control signal cable

- ▶ Direct the control signal cable (1) outwards through the designated cable gland (2) on the top of the Backup-Box.
- ▶ Connect the control signal cable (1) in the storage system as shown in section Connecting the control signal cable [P. 29].

5.5.5 Using the signalling contact

The signalling contact is a potential-free contact. It can be used to indicate the operating status of the Backup-Box. When consumers are supplied with power from the public electrical grid, the contact is open. In backup operation the contact is closed.

5.6 Connection to the storage system

DANGER

Electrical work on the storage system

Danger to life due to electrocution!

- ▶ Switch off the storage system to electrically isolate it.
- ▶ Disconnect the relevant electrical circuits.
- ▶ Secure against anyone switching on the device again.
- ▶ Wait five minutes so the capacitors can discharge.
- ▶ Check that the device is disconnected from the power supply.
- ▶ Only licensed electricians are permitted to carry out electrical work.

5.6.1 Routing cables into the storage system



If no blanking plug or cable gland is used or if they aren't properly attached, the protection class specified for the storage system could be reduced.

Depending on the storage system model, different openings on the connection panel of the storage system can be used to route the cables from the Backup-Box into the storage system.

- ▶ Direct the cables (plus (positive) battery cable, minus (negative) battery cable, earthing cable and control signal cable) into the storage system. **For this, use one of the following options:**

Option 1 - Cable entry plate on storage system

For most storage system models, a round cable entry plate with pre-stamped holes is mounted as a blanking plug on the connection panel.

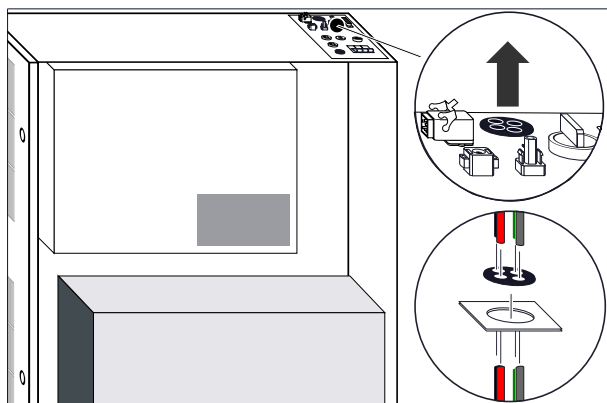

Illustration 14: Cable entry on the storage system

- ▶ Remove the plug and open the pre-stamped holes with a suitable tool (e. g. a screwdriver).
- ▶ Reinstall the cable entry plate in the opening of the storage system.
- ▶ Direct the four lines through the cable entry plate into the inside of the storage system.

Option 2 - Supplied cable entry plate

The round cable entry plate in the scope of delivery can be used if the storage system has blanking plugs that don't have pre-stamped cable entries.

- ▶ Proceed with the supplied cable entry plate as described for option 1.

Option 3 - Supplied blanking plugs

For older hybrid storage systems models, it may be the case that there is no matching opening for the supplied cable entry plate. Then the two supplied blanking plugs with membrane grommet can be used.

- ▶ Remove the two blanking plugs that are shown in the following illustration:



Illustration 15: Blanking plugs on the storage system

- ▶ Using a suitable tool, make appropriate openings in the membrane of the supplied blanking plugs.
- ▶ Attach the plugs in the openings of the storage system.
- ▶ Pass the two battery cables and the earthing cable through the larger plug.
- ▶ Pass the control signal cable through the second plug.

Alternative: Cable gland with multiple sealing insert

Instead of the existing or supplied cable entry options, cable glands can also be used, which needs to be selected depending on the diameter of the opening in the storage system. It is important to use a multiple sealing insert if several lines are being led through one cabled gland.

5.6.2 Connecting the earthing cable

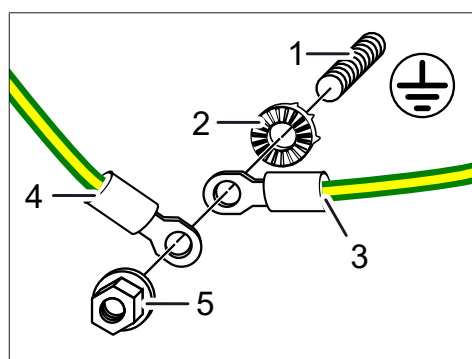

Illustration 16: Connecting the earthing cable

- 1 Earth bolt in the storage system control cabinet
- 2 Contact disc
- 3 Earthing cable, coming from the Backup-Box
- 4 Earthing cable, already connected
- 5 Self-locking nut

- ▶ Connect the earthing cable to an earth bolt inside the storage system.
- Ensure that the components are arranged in the order shown in the illustration.
- ▶ Tighten the self-locking nut with a torque of 5 Nm.

5.6.3 Connecting the battery cables

NOTICE

Mechanical or electrical overload of the branch terminals

Damage to components!

- ▶ Position the two branch terminals in the control cabinet of the storage system in such a way that they are not exposed to and also cannot cause any mechanical or electrical overload.

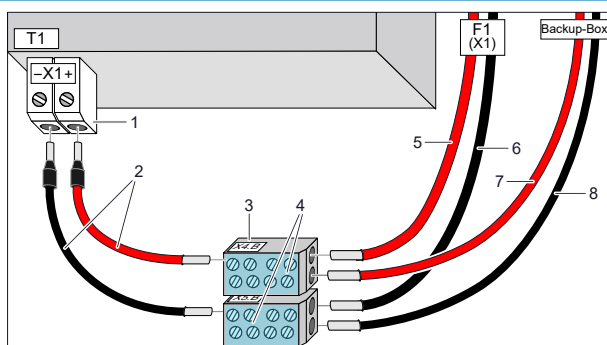

Illustration 17: Connecting the battery cables on the storage system inverter

- | | |
|----------------------------------------------|--------------------------------------|
| 1 Terminal T1-X1 on the inverter | 5 Plus line coming from F1 |
| 2 Plus and minus line from scope of delivery | 6 Minus line coming from F1 (or X1) |
| 3 Branch terminal from scope of delivery | 7 Plus (positive) line - Backup-Box |
| 4 Screw terminals of the branch terminals | 8 Minus (negative) line - Backup-Box |

- ▶ Remove both of the battery lines which are already connected (5 + 6) from terminal strip T1-X1 on the battery inverter (1).
- ▶ Remove the wire end ferrules on the two lines (5 + 6). To do so, pinch off the lines as close as possible under the wire end ferrules.
- ▶ *If necessary:* Shorten the battery lines from the scope of delivery (2) and the lines coming from the Backup-Box (7 + 8).
- ▶ Strip each shortened line to a length of 20 mm.
- ▶ Attach the supplied wire end ferrules to the shortened lines properly.
- ▶ Connect the individual lines as shown in the illustration above.
- ▶ Tighten the screws of the **terminal strip T1-X1** with a torque of **4 Nm**.

The branch terminals have two different terminals, each of which differs by the permissible cable cross-section.

Tighten the both screws of each terminal with the following torques:

- ▶ Terminal up to 25 mm²: 2.5 Nm
- ▶ Terminal up to 35 mm²: 3.5 Nm
- ▶ Finally, insulate the screw terminals of the branch terminals (4) with a suitable insulating tape.

5.6.4 Connecting the control signal cable

The control signal cable needs to be connected in different ways depending on the installation of the storage system in question.

- ▶ Select the applicable option and connect the control signal cable of the Backup-Box as described in the relevant section.

Option 1: no digital inputs/outputs.

If no signal cable is connected in the storage system and routed out, the control signal cable must be routed into the storage system and connected there; see section Variant 1: Connecting the control signal line in the storage system [P. 29].

Option 2: digital inputs/outputs via D-SUB.

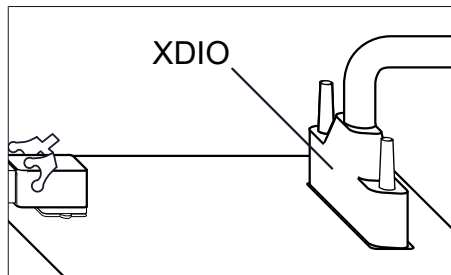

Illustration 18: Digital inputs/outputs (XDIO) via D-SUB

If the signal cable is already connected to the storage system via D-SUB connector, this signal cable can be connected to the control signal cable of the Backup-Box; see section Option 2: connecting the control signal cable to the signal cable (D-SUB) [P. 30].

Option 3: digital inputs and outputs via M-connector.

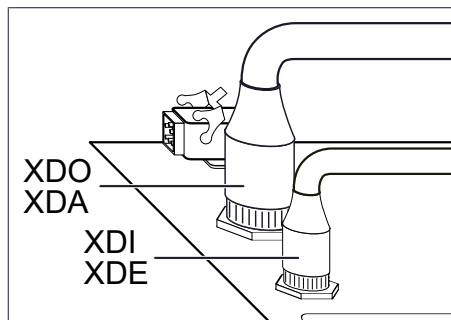

Illustration 19: Digital inputs and outputs via M-connector

If the digital inputs **and** the digital outputs are connected to the storage system via 'M-connectors', these can be connected to the control signal cable of the Backup-Box; see section Option 3: connecting the control signal cable to the signal cable (M-connector) [P. 31].

5.6.4.1 Variant 1: Connecting the control signal line in the storage system



The position of the connections specified in this section may vary depending on the storage system model. Please note the relevant labelling for the individual components in the storage system.

- ▶ Connect the wires of the control signal cable to the following terminals in the storage system:

Wire colour	Function	Connection to terminal
white	GND (earth)	Free terminal at terminal strip X1
brown	Supply voltage 24 V DC	Free terminal at terminal strip X1
yellow	DO for emergency shutdown	K20-X24:5
green	DI for grid detection (backup supply active)	K20-X23:9

Connection to the control unit K20

- Component K20 is the storage system control unit on the inside of the door of the main cabinet.

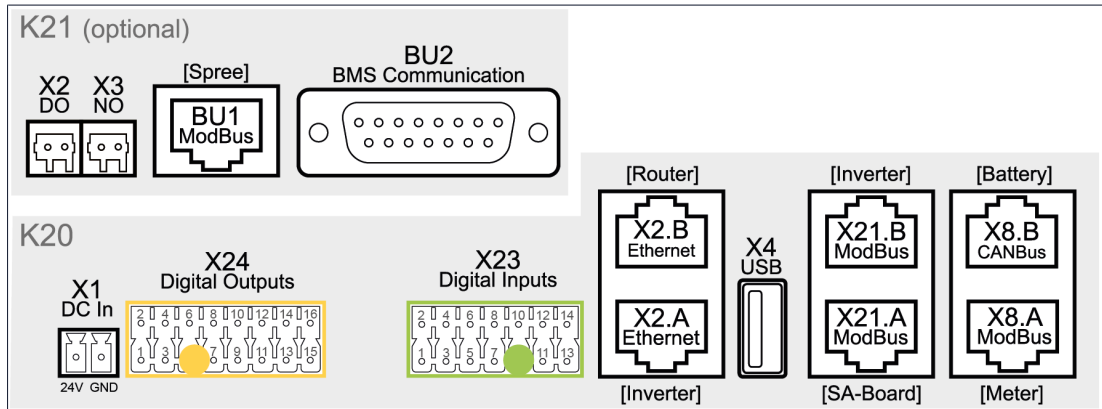

Illustration 20: Connectors of the control unit K20

- Some storage system models require the BU2 connector to be removed in order to work on the terminals X24 und X23. Make sure to attach the plug after work and tighten the knurled screws!
- Plug X23:9 may already be preassigned on the K20. If this is the case, proceed as follows:
 - ▶ Using a suitable slotted screwdriver, open the lock on the terminal on the plug and remove the wire.
 - ▶ Connect the green wire of the control signal cable instead.
 - ▶ Strip the removed wires and fix to the inside of the door of the control cabinet in such a way that they have no contact with live parts.

Connection to terminal strip X1

- Terminal strip X1 is located in the storage system to the right of the inverter.
- Multiple free terminals may be available for the white (GND) and brown (24 V DC) wires.
- The power supply unit is labelled as component T2.

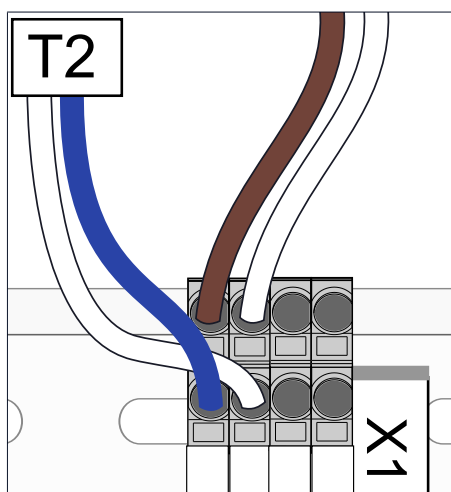

Illustration 21: Example of the connection to X1

- ▶ Follow the course of the blue (24 V DC) and white (GND) wire coming from the power supply to identify the corresponding terminals.
- ▶ Connect the white (GND) and brown (24 V DC) wire to the selected terminals.

5.6.4.2 Option 2: connecting the control signal cable to the signal cable (D-SUB)

- ▶ Observe the information in the storage system product documents for connecting and using the signal cable.

- ▶ Connect the control signal cable of the Backup-Box and the signal cable of the storage system as specified in the following table:

Wire colour of control signal cable for Backup-Box	Function	Wire colour of D-SUB signal cable
White	GND	White
Brown	24 V DC	Grey-pink
Yellow	DO for emergency shutdown	Red
Green	DI grid detection	White-green

5.6.4.3 Option 3: connecting the control signal cable to the signal cable (M-connector)

- ▶ Observe the information in the storage system product documents for connecting and using the signal cable.
- ▶ Connect the control signal cable of the Backup-Box and the two signal cables of the storage system as specified in the following table:

Wire colour of control signal cable for Backup-Box	Function	Wire colour of digital outputs	Wire colour of digital inputs
White	GND	White	-
Brown	24 V DC	-	Brown
Yellow	DO	Red	-
Green	DI	-	Blue

6 Commissioning

6.1 Commissioning checklist

Check the following points before switching on the storage system and therefore also the Backup-Box:

- ✓ All cables are completely and correctly connected.
- ✓ A three-pole miniature circuit breaker (max. nominal current 32 A, type C) is installed upstream of the input for the Backup-Box.
- ✓ All consumers in the backup circuit are protected by a residual current device with a maximum nominal differential current of 30 mA.
- ✓ The electrical cables meet the requirements of all local and national guidelines for cable dimensions.
- ✓ The earth connection between the Backup-Box and main earthing terminal is in place and has a cross-section of 10 mm² (CU cross-section or equivalent).

6.2 Switching on the Backup-Box and the storage system

To switch on the storage system and the Backup-Box, the following steps must be performed in the given order:

1. Ensure, that storage system and Backup-Box are disconnected from the power supply
2. Ensure, that the F1.B miniature circuit breaker inside the Backup-Box is switched on.
3. Switch on the grid voltage to the storage system and the Backup-Box using the respective miniature circuit breakers in the mains line.
4. Switch on the storage system as described in the respective installation instructions.

6.3 Setting up the Backup-Box

Conditions:

- ✓ The storage system is connected to the router of the home network.
- ✓ Your laptop or PC also accesses the home network.
 - ▶ Navigate to the following internet address: <https://find-my.sonnen-batterie.com>
 - ▶ Start the **commissioning assistant 2**.
 - ▶ Run through the commissioning assistant and activate the Backup-Box at the appropriate point. The emergency buffer can also be set. This buffer can be changed at a later point as described in the following section.

6.4 Setting the backup buffer

Proceed as follows to set what percentage of the capacity of the storage system should be available for the Backup-Box in the event of a grid outage.

- ▶ On the web interface of the storage system, navigate to the **Settings** page.
- ▶ Change the percentage for 'backup-buffer' to a desired value.

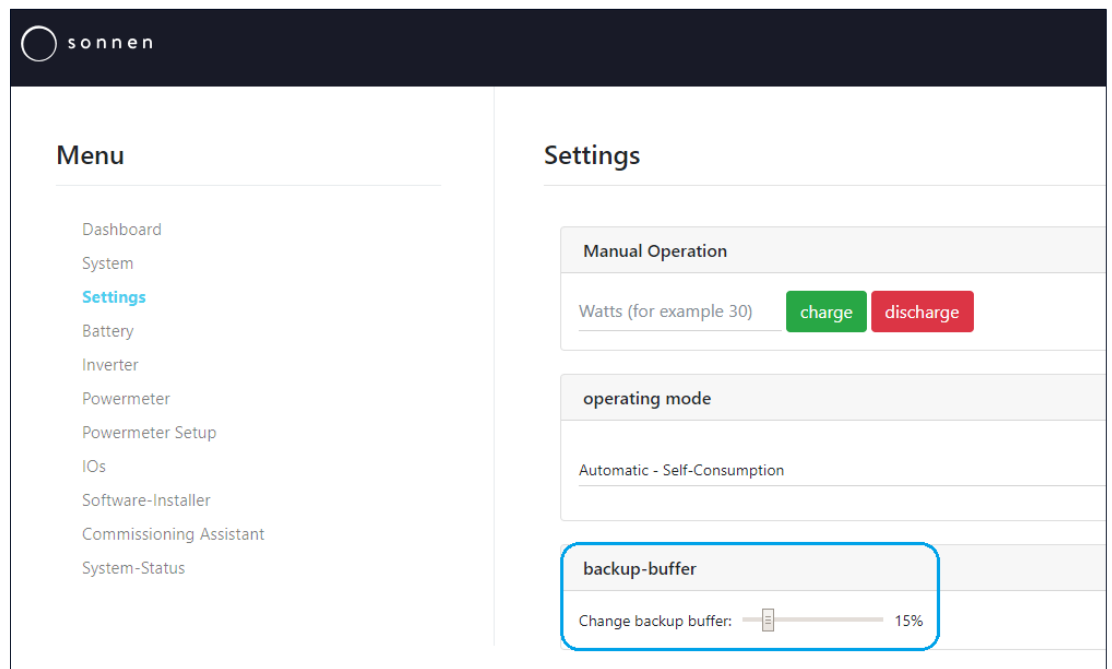

Illustration 22: Settings page

6.5 Testing backup operation

1. Simulate a grid outage

- ▶ Switch the main fuses in the building off, so that the Backup-Box and storage system are no longer connected to the public electrical grid. The storage system switches to backup operation after switching off the fuses.

2. Activate a consumer in the backup circuit

- ▶ Activate a consumer connected to phase L1.

3. Check backup power supply

Backup operation operates properly when the consumer connected to phase L1 is receiving electrical power and the sonnen Eclipse on the Backup-Box lights up white.

If the backup operation does not work:

- ▶ Check the electrical wiring (see Electrical installation [P. 17]).
- ▶ Contact sonnen customer service if the problem cannot be resolved.

6.6 Filling in the commissioning report

The commissioning report needs to be filled in for the initial commissioning.

- ▶ Complete the commissioning report in the appendix of the document in full.
- ▶ Make a copy of the filled in commissioning report, the original remains with the operator.
- ▶ Send a scan of the commissioning report to the following e-mail address within 5 working days: service@sonnen.de and support@sonnen.com.au

7 Decommissioning

NOTICE

Deep-discharge of the battery modules

Destruction of the battery modules!

- ▶ Do not disconnect the storage system from the public grid for long periods of time.
- ▶ Never continue to operate battery modules which have been deep-discharged.

7.1 Switching off the Backup-Box

To switch off the Backup-Box manually, the following procedure can be carried out. In order to be able to work on the Backup-Box safely it must be disconnected from the power supply (see next section).

1. Disconnect the power supply to the storage system as described in the relevant product documentation.
2. Wait at least five minutes until the internally stored energy inside the storage system inverter has discharged.

7.2 Disconnecting the Backup-Box from the power supply

Before **working on** the Backup-Box, it must be completely disconnected from the power supply.

1. Switch off the Backup-Box by disconnecting the power supply to the storage system (as described in the relevant product documentation).
2. Switch off the grid voltage using the miniature circuit breaker for the Backup-Box.
3. Take steps to ensure that these switches cannot be switched on again.
4. Wait at least five minutes until the internally stored energy inside the storage system inverter has discharged.
5. Carefully check that there is no voltage inside the Backup-Box.

8 Uninstallation and disposal

8.1 Uninstallation

⚠ DANGER

Improper uninstallation of the Backup-Box

Danger to life due to electrocution!

- ▶ The Backup-Box must only be uninstalled by licensed electricians.

8.2 Disposal

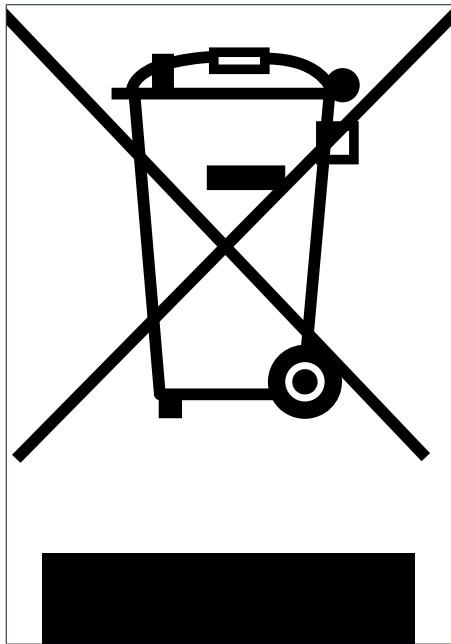

Illustration 23: WEEE symbol

The Backup-Box must not be disposed of as domestic waste!

- ▶ Dispose of the Backup-Box in an environmentally friendly way through suitable collection systems.

9 Troubleshooting

Fault	Possible causes	Rectification
Grid operation (no grid outage)		
The electrical consumers in the building are not supplied with energy in grid operation.	The mains cables (AC lines) have not been correctly connected.	Check the electrical wiring of the mains cables (see Connecting the mains cables [P. 24]).
	The F1.B miniature circuit breaker in the Backup-Box is switched off.	Switch on the F1.B miniature circuit breaker inside the Backup-Box .
Backup operation (grid outage) - Backup operation does not start		
Backup operation doesn't start. The sonnen Eclipse of the storage system and the Backup-Box is off .	The batteries of the storage system have discharged so much that further discharging would lead to a deep discharge state and therefore damage the batteries.	The only thing to do is wait until the grid outage passes, the public electrical grid once again starts supplying electrical energy and the Backup-Box automatically switches to grid operation.
	The storage system is switched off.	Switch on the storage system.
Backup operation doesn't start. The sonnen Eclipse of the storage system pulses orange . The sonnen Eclipse of the Backup-Box is off .	Electrical consumers with too high power consumption are connected to phase L1.	Switch off electrical consumers or reduce their power consumption.
		Only connect electrical consumers to phase L1 when they have a power consumption that does not exceed the nominal power or (when switching on) the maximum power of the Backup-Box .
Backup operation doesn't start. The sonnen Eclipse of the storage system illuminates red . The sonnen Eclipse of the Backup-Box is off .	The storage system has detected a problem.	Please contact the sonnen service team to get help resolving the problem.
Backup operation (grid outage) - Backup operation stops		
Backup operation stops. The sonnen Eclipse of the storage system and the Backup-Box is off .	The batteries of the storage system have discharged so much that further discharging would lead to a deep discharge state and therefore damage the batteries.	The only thing to do is wait until the grid outage passes, the public electrical grid once again starts supplying electrical energy and the Backup-Box automatically switches to grid operation.
	The control of the storage system detected an overload, this means there are electrical consumers connected to phase L1 with a too high power consumption.	Switch off electrical consumers so that the power consumption does not exceed the nominal power or (when switching on) the maximum power of the Backup-Box . The storage system automatically restarts the backup operation as soon as the overload is no longer present.
Backup operation doesn't stop. The sonnen Eclipse of the storage system illuminates red . The sonnen Eclipse of the Backup-Box is off .	The storage system has detected a problem.	Please contact the sonnen service team to get help resolving the problem.

Commissioning report sonnenBackup-Box

- The completed commissioning report must be sent to the following email addresses within 5 working days of successful commissioning: **service@sonnen.de** and **support@sonnen.com.au**

Commissioning details

sonnenBackup-Box serial number

sonnenBatterie serial number

Date of commissioning

Operator details

Customer number (sonnenCommunity)

sonnenContract-ID (sonnenFlat) (if existing)

Surname, first name

Street

Post code, town

Telephone

Email address

Critical consumers

The following critical consumers (consumers with high power consumption/inductivity/capacity) are connected at phase L1 (backup phase):

Special notes / points to be addressed

Electrician's declaration

Commissioning checklist (please tick)

- A three-pole miniature circuit breaker (max. nominal current 32 A, type C) is installed upstream of the input for the Backup-Box.
- All consumers in the backup circuit are protected by a residual current device with a maximum nominal differential current of 30 mA.
- The electrical cables meet the requirements of all local and national guidelines for cable dimensions.
- The earth connection between the Backup-Box and main earthing terminal is in place and has a cross-section of 10 mm² (CU cross-section or equivalent).
- Backup operation has been successfully tested.
- I confirm that my details are correct.
- The sonnenBackup-Box was installed and commissioned by me in the proper manner. I followed the installation instructions in doing so.

Place, date

Electrician's signature

Operator's declaration

- I confirm that my details are correct.

Place, date

Operator's signature

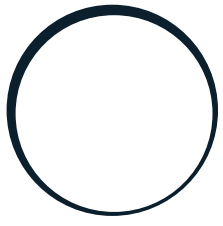

sonnen

energy is yours